

NSV Valve Corporation Ltd.

Sanqiao Industrial Zone, Oubei Street,

Yongjia, Zhejiang, China 325105

Tel: 86-577-67378616

Fax: 86-577-67372367

E-mail: sales@nsvvalve.com

Website: www.nsvvalve.com



NSV®



Ball Valves

General

Since 1950 Ball valve has been available as a valve and become one of the fastest-growing varieties of the valves in the last decades. Ball valve is not only of simple structure, good sealing, but also of smaller size, lighter weight, lower cost, easier installation, less driving torque value, easier operation, quicker opening and closure to a certain nominal range. During the past 50 years, Ball has developed into one of the main valve of the category. Ball valve can be used to cut off or access medium, and also control or regulate the fluid, while the V-ball valve can achieve more precise flow regulation and control. As one of the leading Chinese manufacturers of industrial valves is well capable of the production for various types of industrial valves, ball valves have been serving in a wide range of rigorous conditions and demand of oil, natural gas, refining, petrochemicals, ships, power plants, as well as Pipeline industry. Production of the ball valve is in full compliance

The ball valve structure

1. Small fluid resistance: The ball valve is of least fluid resistance in all types of valves, even reduced bore ball valve, the fluid resistance is quite small.
2. Quick and easy opening and closing: as long as the stem turns 90°, the ball valve will be able to complete the full open or closure actions.
3. Good sealing performance: the general use of ball valve seat ring, such as PTFE flexible materials, is easy to achieve sealing performance, and the sealing capability increases with the power of the medium pressure.
4. Reliable stem sealing: because of the rotation actions of the operation, the stem Packing seals will not be easily destroyed, and the sealing capability increases with the power of the medium pressure.
5. Easy remote control: since the control of the ball valve needs only 90° rotation, it is easy to control and automate the remote control, so the ball valve can be mounted with pneumatic actuator, electrical actuator, hydraulic actuator, gas-liquid interaction actuator, or electro-hydraulic interaction actuator.
6. Smooth channel disables easy medium deposition, ensures smooth pipeline transit.

Floating ball valve features

Floating ball structure is simple and a good seal for class 150-class 600 pressure class to cut off or access the medium in all kinds of pipeline. Ball valve with different materials, can be applied to water, steam, oil products, liquefied natural gas, gas, nitric acid, acetic acid, such as oxidizing medium. One-piece ball valve includes: one-piece type, and forged split body type. All the floating ball are in accordance with API 608/BS 5351, and other standard design, fire test to meet the requirements of API 607, pressure range: class 150-class 600; operating temperature range: -196°C~540°C; size range: NPS 1/2~NPS 8.

Fire Safe Design

When the ball valve site happens to be on fire, and non-metallic sealing materials are destroyed after pyrolysis, ball valve with specially designed metal to metal seal auxiliary structure, can achieve effective control of valve in and out leakage.

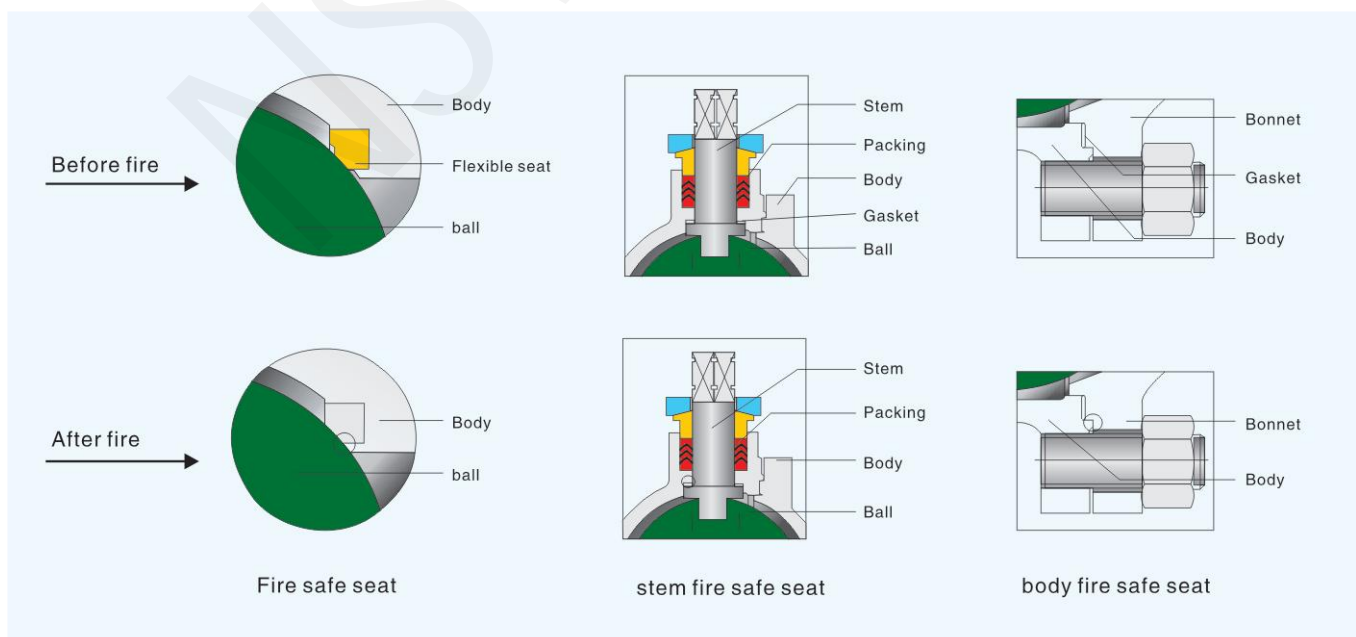

■ **Stem blow-out proof design**

Stem blow-out proof adopts the structural design of the T-shaped structure as a whole, even if the valve chamber is in the unusual pressure arising condition, as well as extreme cases like gland failure, the design can guarantee that stem will not be blown out by the medium. With the stem installed deep inside the valve body, it can function as the backseat which increases with the medium pressure and achieves reliable sealing in a variety of pressure conditions.

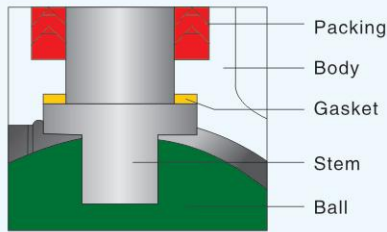

Stem deeper installed ensures blow-out proof

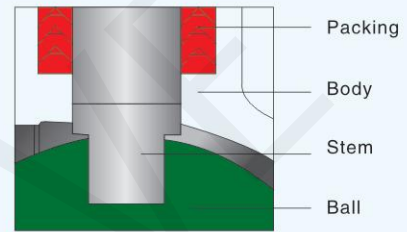

Stem normal installed is easily blown out

■ **Anti-static design**

Floating ball valve anti-static design adopts anti-static spring structure or steelstatic extraction device, so that the body between the ball forms an electrostatic channel (NPS = 1 of the ball) or through the stem between the valve body and the ball forms a static channel (NPS = 1-1/2 of the ball), and thus ensures the static electricity generated by friction in the process be grounded into the earth through the body, to avoid static electricity sparks that could cause an explosion or fire danger and so on.

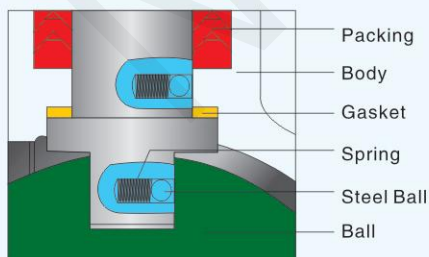

NPS ≥ 1-1/2 anti-static design

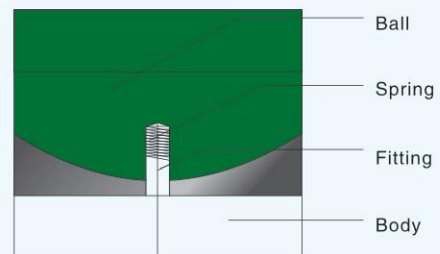

NPS ≥ 1 anti-static design

■ Fugitive emission design

Adopts dynamic loading gland design and the V-packing seals that ensures continuous loading to the gland and guarantees lasting close sealing. prevents medium from leaking. Meanwhile the V-fill packing gland can compress the power and medium power effectively into the valve stem sealing.

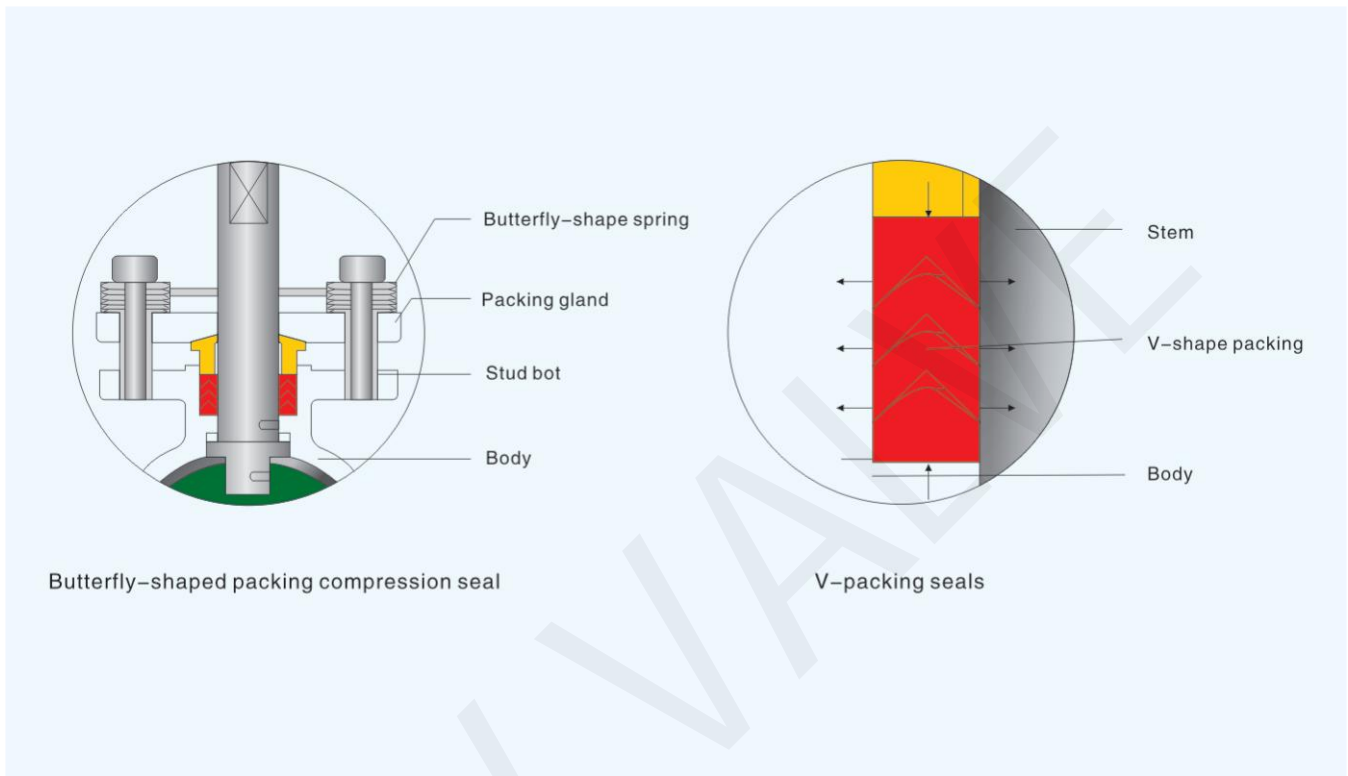

■ The stem wear proof and misoperation proof

Design has changed the traditional packing gland into packing gland and bushing with spherical contact to ensure that the bushing always stay vertical. Inside the bushing there sets a PTFE bush to avoid the wear and reduce torque valve operation. The structural design to prevent the misoperation is set up with the approach of the 90° position locking devise that can be locked to prevent the misoperation. Stem head adopts flat head design. when opening the valve, the handle is parallel to the pipeline; when closing the valve, the handle is vertical to the pipeline, to ensure that the prevention of misoperation.

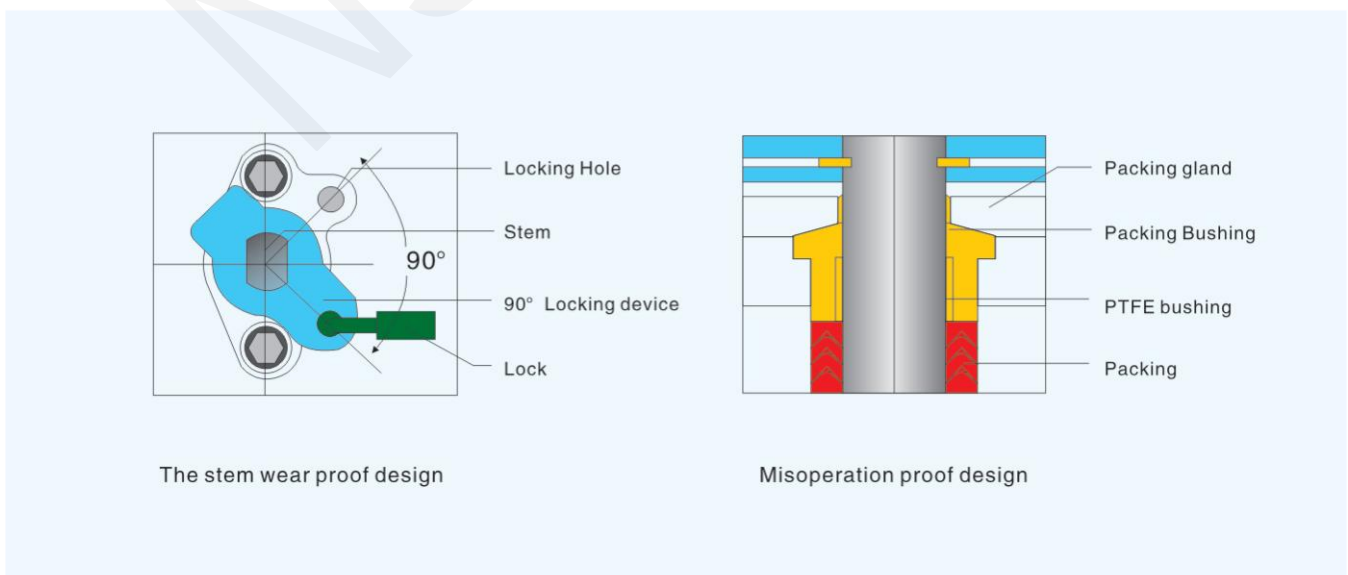

One-piece, side-entry, floating ball valve

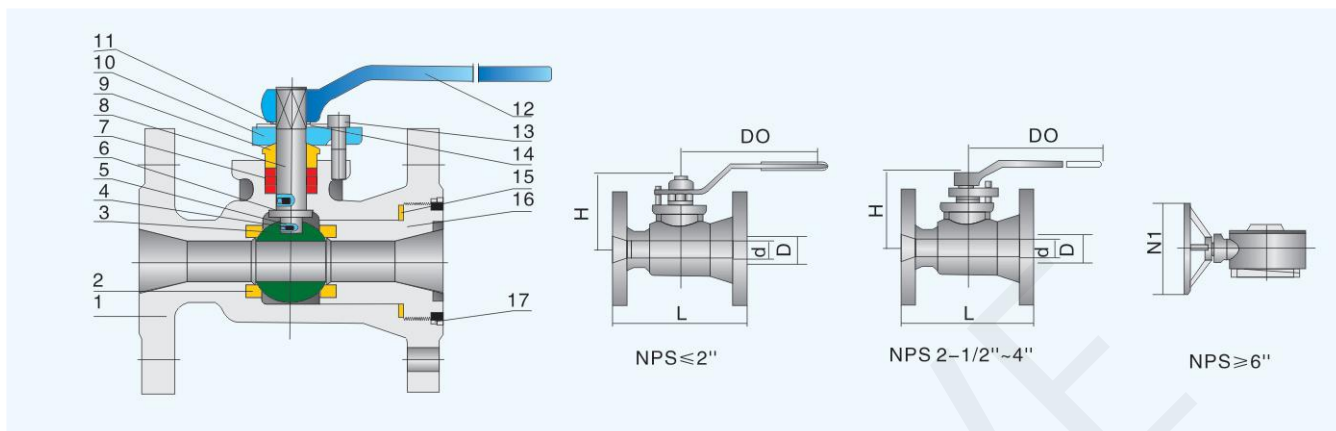

Material List

| No | Parts | Material |
|----|---------------------|----------------------|
| 1 | Body | ASTM A216 Gr.WCB |
| 2 | Seat | PTFE |
| 3 | Ball | 304 S.S. |
| 4 | Steel Ball | 304 S.S. |
| 5 | Spring | 304 S.S. |
| 6 | Gasket | 304 S.S.+Graphite |
| 7 | Packing | Graphite |
| 8 | Stem | ASTM A182 F6a |
| 9 | Bushing | ASTM A276 410 |
| 10 | Gland | ASTM A216 Gr.WCB |
| 11 | Gauge Block | AISI 1010Zinc-coated |
| 12 | Handle | ASTM A216Gr.WCB |
| 13 | Nut | ASTM A193 Gr.B7 |
| 14 | Retaining Ring | 304 S.S. |
| 15 | Body Fire Safe Ring | 304S.S. |
| 16 | Bonnet | ASTM A216 Gr.WCB |

Standards

Face-to-Face dimension: ASME B 16.10
 Design and manufacture: API 608, BS 5351, API 6D
 Flanged End: ASME B16.5
 Shell Wall Thickness: BS 5351, ASME B16.34
 Valve Test: API 598

Features

Under medium pressure, the ball can have a certain amount of displacement and be pressed at the valve seat ring exit and achieves sealing. Floating ball valve structure is simple and of good seal, but since the full load from the ball under pressure is transferred to the ring at exit, its use is restricted in a certain range of pressure size, generally floating ball valve is applicable to low pressure in small size valve. One-piece ball valve was developed from many years of manufacturing experience. It's of side entry, simple structure, light weight, good sealing, low torque value, and different sealing materials that can meet different temperature range.

The body material is also available LCB, A351 CF8, CF8M, CF3, CF3M, duplex stainless steel etc. The trim/seat material can be customized upon request.

Dimensions & Weights

Class 150

| NPS(in) | L(mm) | D(mm) | d(mm) | H(mm) | W(mm) | W1(mm) | WT(kg) |
|---------|-------|-------|-------|-------|-------|--------|--------|
| 1/2 | 108 | 12.7 | 9.5 | 54 | 140 | -- | 2.1 |
| 3/4 | 117 | 19 | 12.7 | 59 | 140 | -- | 3 |
| 1 | 127 | 25.4 | 19 | 64 | 160 | -- | 4.1 |
| 1-1/2 | 165 | 38 | 30 | 90 | 160 | -- | 6.5 |
| 2 | 178 | 51 | 38 | 102 | 260 | -- | 9 |
| 2-1/2 | 190 | 64 | 51 | 112 | 260 | -- | 11.2 |
| 3 | 203 | 76 | 64 | 121 | 260 | -- | 15.3 |
| 4 | 229 | 102 | 76 | 166 | 320 | -- | 28.6 |
| 6 | 267 | 152 | 114 | 208 | -- | 450 | 53 |
| 8 | 292 | 203 | 144 | 246 | -- | 660 | 81 |
| 10 | 330 | 254 | 187 | 303 | -- | 660 | 150 |

Class 300

| NPS(in) | L(mm) | D(mm) | d(mm) | H(mm) | W(mm) | W1(mm) | WT(kg) |
|---------|-------|-------|-------|-------|-------|--------|--------|
| 1/2 | 140 | 12.7 | 9.5 | 54 | 140 | -- | 2.8 |
| 3/4 | 152 | 19 | 12.7 | 59 | 140 | -- | 3.6 |
| 1 | 165 | 25.4 | 19 | 64 | 160 | -- | 4.9 |
| 1-1/2 | 190 | 38 | 30 | 90 | 160 | -- | 10.4 |
| 2 | 216 | 51 | 38 | 102 | 260 | -- | 12 |
| 2-1/2 | 241 | 64 | 51 | 112 | 260 | -- | 16.1 |
| 3 | 282 | 76 | 64 | 121 | 260 | -- | 23 |
| 4 | 305 | 102 | 76 | 166 | 320 | -- | 39.5 |
| 6 | 403 | 152 | 114 | 208 | -- | 450 | 82 |
| 8 | 419 | 203 | 144 | 246 | -- | 660 | 124 |
| 10 | 457 | 254 | 187 | 303 | -- | 660 | 206 |

Standards

Face-to-Face dimension: ASME B 16.10, JIS B2002
 Design and manufacture: API 608, BS 5351, API 6D, JIS B2071, B2081
 Flanged End: ASME B16.5, JIS B2212, B2214
 Shell Wall Thickness: BS 5351
 Valve Test: API 598, JIS B2003
 Pressure-temperature Rating: JIS B2071, B2081

The body material is also available LCB, A351 CF8, CF8M, CF3, CF3M, duplex stainless steel etc. The trim/seat material can be customized upon request.

Material List

| No | Parts | Material |
|----|----------------------|-----------------------|
| 1 | Body | ASTM A216 Gr.WCB |
| 2 | Ball | 304 S.S. |
| 3 | Spring | 304 S.S. |
| 4 | Nut | ASTM A194 Gr.2H |
| 5 | Stud | ASTM A193 Gr.B7 |
| 6 | Nut | ASTM A193 Gr.B7 |
| 7 | Gauge Block | AISI 1010 Zinc-coated |
| 8 | Handle | ASTM A216 Gr.WCB |
| 9 | Gland | 304 S.S. |
| 10 | Packing Gland | ASTM A216 Gr.WCB |
| 11 | Packing Bushing | ASTM A276 410 |
| 12 | Packing | PTFE |
| 13 | Stem | ASTM A182 F6a |
| 14 | Bonnet | ASTM A216 Gr.WCB |
| 15 | Gasket | PTFE |
| 16 | Seat | PTFE |
| 17 | Inner-firesafe Metal | ASTM A276 410 |
| 18 | Outer-firesafe Metal | ASTM A276 410 |

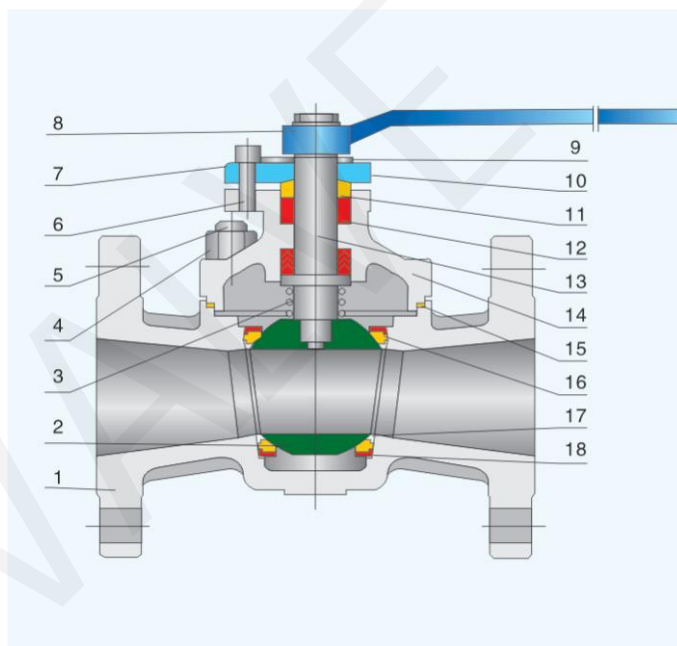

Features

Self-developed dual-slope ball valve, it can be widely used in the petroleum chemical, metallurgical, electricity, medicine and technology sectors such as technology and instrumentation on the pipeline, and serves for general medium and also sewage containing fiber, micro-granular, high viscosity of the fluid medium. Dual-slope ball valve under the performance of the spring, can automatically adjust the seal along the seat, valve body, and the ball to ensure reliable sealing under low and medium pressure conditions. The sealing between the stem and bonnet contact area comes from the compaction sealing from the stem and bonnet convex against the packing surface which effectively reduces the torque for opening and valves. This type also applies top entry design that makes easier to carry out repair or replacement of parts directly on the pipeline, to achieve more convenient maintenance.

Fire Safe Design

To prevent from a large amount of leakage when the seat material is damaged in the fire, dual-slope ball valve applies a fire safe metal ring between the valve seat so when the seat is on fire, the ball will contact with the metal ring and save the sealing to ensure the prevention of the medium from leakage and the safety of the pipeline.

Stem blow-out proof Design

To prevent the stem from being blown out by the medium in the unusual pressure arising condition, dual-slope ball valve adopts a convex with the stem blow-out proof at the bottom of the stem to achieve effective control of the ball valve stem.

Packing flat surface tightness

To reduce the opening torque value, and enable the quick and convenient operation, dual-slope ball valve applies the pre-tightening force of the spring to the surface between the packings and the that between the stem shoulder and the cover shoulder to ensure tightness.

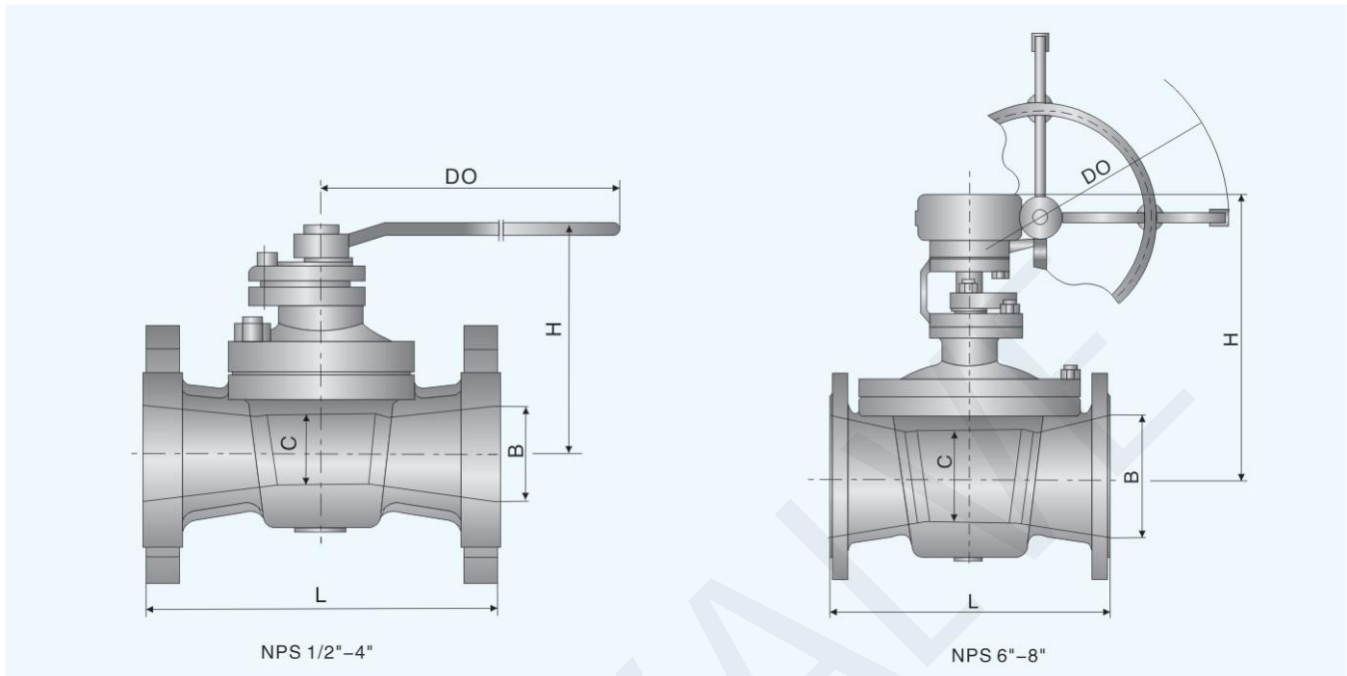

Dimensions & Weights

■ **Class 150**

| NPS(in) | L(mm) | C(mm) | B(mm) | H(mm) | Do(mm) | W1(mm) | WT(KG) |
|---------|-------|-------|-------|-------|--------|--------|--------|
| 1/2 | 108 | 9.5 | 13 | 100 | 140 | -- | 2.8 |
| 3/4 | 117 | 13 | 19 | 100 | 140 | -- | 3.2 |
| 1 | 127 | 20.6 | 25 | 100 | 140 | -- | 4.0 |
| 1-1/2 | 165 | 30.2 | 38 | 120 | 190 | -- | 8.8 |
| 2 | 178 | 38 | 51 | 140 | 230 | -- | 11.0 |
| 2-1/2 | 190 | 51 | 63 | 180 | 320 | -- | 22.0 |
| 3 | 203 | 57.2 | 76 | 210 | 320 | -- | 25.2 |
| 4 | 229 | 76.2 | 102 | 220 | 450 | -- | 36.0 |
| 6 | 394 | 114.3 | 152 | 320 | -- | 450 | 147.0 |
| 8 | 457 | 152.4 | 203 | 380 | -- | 660 | 198.0 |

■ **Class 300**

| NPS(in) | L(mm) | C(mm) | B(mm) | H(mm) | Do(mm) | W1(mm) | WT(KG) |
|---------|-------|-------|-------|-------|--------|--------|--------|
| 1/2 | 140 | 9.5 | 13 | 100 | 140 | -- | 3.1 |
| 3/4 | 152 | 13 | 19 | 100 | 140 | -- | 4.3 |
| 1 | 165 | 20.6 | 25 | 100 | 140 | -- | 4.4 |
| 1-1/2 | 190 | 30.2 | 38 | 120 | 190 | -- | 12.6 |
| 2 | 216 | 38 | 51 | 140 | 230 | -- | 14.0 |
| 2-1/2 | 241 | 51 | 63 | 180 | 320 | -- | 23.8 |
| 3 | 282 | 57.2 | 76 | 210 | 320 | -- | 38.6 |
| 4 | 305 | 76.2 | 102 | 220 | 450 | -- | 42.5 |
| 6 | 403 | 114.3 | 152 | 320 | -- | 450 | 150.2 |
| 8 | 502 | 152.4 | 203 | 380 | -- | 660 | 206.2 |

Standards

Face-to-Face dimension: ASME B 16.10 JIS B2002
 Design and manufacture: API 608, BS 5351, API 6D
 Flanged End: ASME B16.5, JIS B2212, B2214
 Shell Wall Thickness: BS 5351
 Valve Test: API 598, JIS B2003
 Pressure-Temperature Rating: JIS B2071, B2081

The body material is also available LCB, A351 CF8, CF8M, CF3, CF3M, duplex stainless steel etc. The trim/seat material can be customized upon request.

Material List

| No | Parts | Material |
|----|-----------------|-----------------------|
| 1 | Body | ASTM A216 Gr.WCB |
| 2 | Seat | PTFE |
| 3 | Ball | 304 S.S. |
| 4 | Stem | ASTM A182 F6a |
| 5 | Gasket | PTFE |
| 6 | Spring | 304 S.S. |
| 7 | Steel Ball | 304 S.S. |
| 8 | Packing | PTFE |
| 9 | Packing Bushing | ASTM A276 410 |
| 10 | Nut | ASTM A193 Gr.B7 |
| 11 | Retaining Ring | 304 S.S. |
| 12 | Lever | ASTM A216 Gr.WCB |
| 13 | Gauge Block | AISI 1010 Zinc-coated |
| 14 | Packing Gland | ASTM A216 Gr.WCB |
| 15 | Body Gasket | PTFE |
| 16 | Bonnet | ASTM A216 Gr.WCB |
| 17 | Stud | ASTM A193 Gr.B7 |
| 18 | Nut | ASTM A194 Gr. 2H |

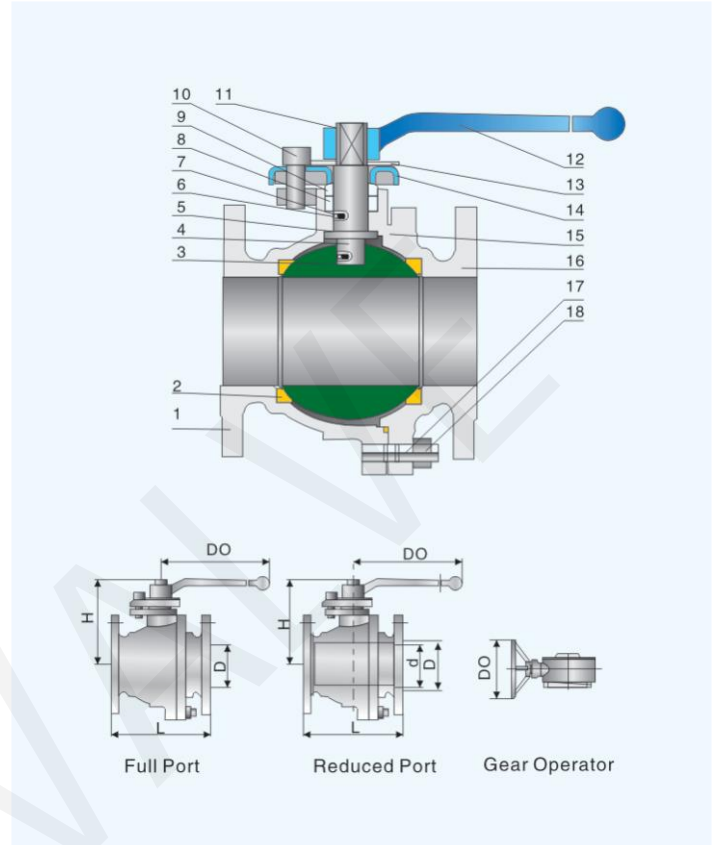

Dimensions & Weights

Class 150/10K

| | NPS(in) | 1/2 | 3/4 | 1 | 1-1/2 | 2 | 3 | 4 | 6 | 8 |
|--------------|-----------|---------|-------|---------|---------|------|------|-------|-------|-------|
| | Full bore | D(mm) | 13 | 19 | 25 | 38 | 51 | 64 | 76 | 102 |
| L(mm) | | 108 | 117 | 127 | 165 | 178 | 203 | 229 | 394 | 457 |
| H(mm) | | 61 | 66 | 76 | 95 | 142 | 156 | 181 | 270 | 345 |
| Do(mm) | | 130 | 130 | 160 | 230 | 400 | 400 | 700 | 300* | 300* |
| WT(kg) | | 2.4 | 3.3 | 4.8 | 8.2 | 15.6 | 19.8 | 32.0 | 94.0 | 162.0 |
| Reduced bore | NPS(in) | 3/4*1/2 | 1*3/4 | 1-1/2*1 | 2*1-1/2 | 3*2 | 4*3 | 6*4 | 8*6 | 10*8 |
| | L(mm) | 117 | 127 | 165 | 178 | 203 | 229 | 267 | 292 | 330 |
| | D(mm) | 19 | 25 | 38 | 63 | 76 | 102 | 152 | 203 | 254 |
| | H(mm) | 82 | 85 | 100 | 120 | 153 | 162 | 191 | 290 | 340 |
| | Do(mm) | 130 | 130 | 160 | 230 | 400 | 400 | 460 | 300* | 300* |
| | d(mm) | 13 | 19 | 25 | 51 | 63 | 76 | 105 | 152 | 203 |
| WT(kg) | 2.6 | 4.5 | 6.0 | 14.6 | 19.0 | 32.5 | 58.0 | 117.0 | 160.0 | |

Class 300/20K

| | NPS(in) | 1/2 | 3/4 | 1 | 1-1/2 | 2 | 3 | 4 | 6 | 8 |
|--------------|-----------|---------|-------|---------|---------|------|------|-------|-------|-------|
| | Full bore | D(mm) | 13 | 19 | 25 | 38 | 51 | 64 | 76 | 102 |
| L(mm) | | 140 | 152 | 165 | 190 | 216 | 282 | 305 | 403 | 419 |
| H(mm) | | 62 | 68 | 80 | 100 | 148 | 162 | 188 | 283 | 360 |
| Do(mm) | | 150 | 150 | 180 | 250 | 400 | 400 | 700 | 300* | 400* |
| WT(kg) | | 3.0 | 3.5 | 6.2 | 11.0 | 25.0 | 40.0 | 57.5 | 128.0 | 252.0 |
| Reduced bore | NPS(in) | 3/4*1/2 | 1*3/4 | 1-1/2*1 | 2*1-1/2 | 3*2 | 4*3 | 6*4 | 8*6 | -- |
| | L(mm) | 152 | 165 | 190 | 216 | 282 | 305 | 403 | 419 | -- |
| | D(mm) | 19 | 25 | 38 | 63 | 76 | 102 | 152 | 203 | -- |
| | H(mm) | 82 | 85 | 100 | 120 | 153 | 162 | 191 | 290 | -- |
| | Do(mm) | 130 | 130 | 160 | 230 | 400 | 400 | 460 | 300* | -- |
| | d(mm) | 13 | 19 | 25 | 50 | 63 | 76 | 102 | 152 | -- |
| WT(kg) | 3.5 | 5.5 | 10.0 | 23.5 | 29.0 | 55.0 | 80.0 | 162.0 | -- | |

Material Lis

| No | Parts | Material |
|----|--------------------|-----------------------|
| 1 | Body | ASTM A105 |
| 2 | Gasket | PTFE |
| 3 | Seat | R-PTFE |
| 4 | Ball | 304 S.S. |
| 5 | Steel Ball | 304 S.S. |
| 6 | Anti-static Spring | 304 S.S. |
| 7 | Stem | ASTM A182 F6a |
| 8 | Gasket | PTFE |
| 9 | Packing | PTFE |
| 10 | Nameplate | SS304 |
| 11 | Position Pin | ASTM 1045 |
| 12 | Nut | ASTM A194 Gr. 2H |
| 13 | Lever | ASTM A216 Gr.WCB |
| 14 | Gauge Block | AISI 1010 Zinc-coated |
| 15 | Bushing Gasket | ASTM 1045 |
| 16 | Nut | ASTM A194 Gr. 2H |
| 17 | Gland | 304 S.S. |
| 18 | Gland Bushing | ASTM A276 410 |
| 19 | Bonnet | ASTM 1045 |
| 20 | Nut | ASTM A194 Gr. 2H |
| 21 | Stud | ASTM A193 Gr.B7 |

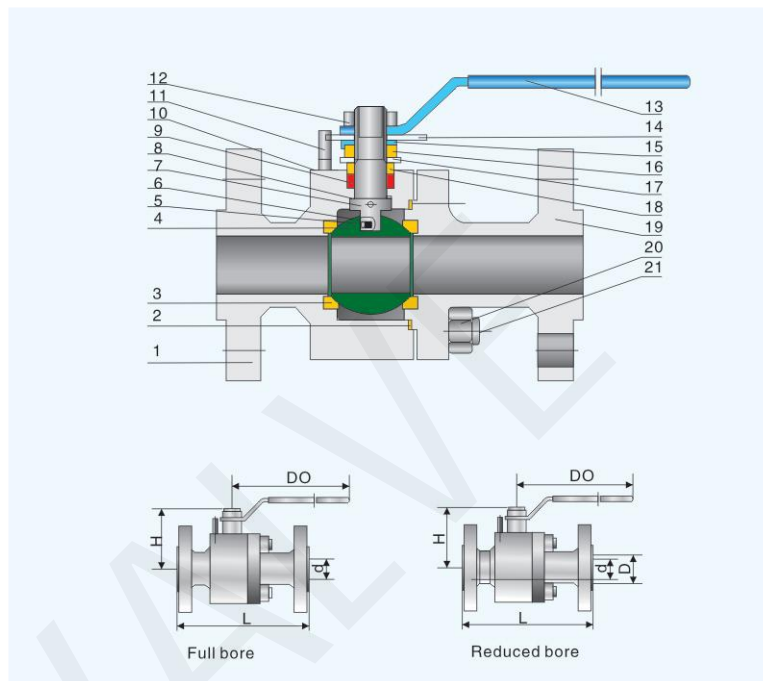

The body material is also available LF2, A182 F304, F316, F304L, F316L, F51 etc. The trim/seat material can be customized upon request.

Dimensions & Weights

Class 600

| | NPS(in) | 1/2 | 3/4 | 1 | 1-1/2 | 2 | 3 |
|--------------|-----------|---------|-------|---------|---------|------|------|
| | Full bore | L(mm) | 165 | 190 | 216 | 241 | 292 |
| D(mm) | | 13 | 19 | 25 | 38 | 51 | 76 |
| H(mm) | | 98 | 103 | 122 | 135 | 151 | 177 |
| Do(mm) | | 140 | 140 | 170 | 260 | 300 | 450 |
| WT(kg) | | 3.0 | 4.8 | 6.5 | 12.0 | 15.0 | 28.0 |
| Reduced bore | NPS(in) | 3/4*1/2 | 1*3/4 | 1-1/2*1 | 2*1-1/2 | 3*2 | -- |
| | L(mm) | 190 | 216 | 241 | 292 | 356 | -- |
| | D(mm) | 19 | 25 | 38 | 51 | 76 | -- |
| | H(mm) | 98 | 103 | 122 | 135 | 151 | -- |
| | Do(mm) | 140 | 140 | 170 | 260 | 300 | -- |
| | d(mm) | 13 | 19 | 25 | 38 | 51 | -- |
| WT(kg) | 2.8 | 3.2 | 5.5 | 7.1 | 12.8 | -- | |

Class 900

| | NPS(in) | 1/2 | 3/4 | 1 | 1-1/2 | 2 | 3 |
|--------------|-----------|---------|-------|---------|---------|------|------|
| | Full bore | L(mm) | 216 | 229 | 254 | 305 | 368 |
| D(mm) | | 13 | 19 | 25 | 38 | 51 | 76 |
| H(mm) | | 115 | 122 | 125 | 157 | 178 | 208 |
| Do(mm) | | 160 | 230 | 230 | 400 | 400 | 500 |
| (kg) | | 4.2 | 9.6 | 13.8 | 21.8 | 39.0 | 58.0 |
| Reduced bore | NPS(in) | 3/4*1/2 | 1*3/4 | 1-1/2*1 | 2*1-1/2 | 3*2 | -- |
| | L(mm) | 229 | 254 | 305 | 368 | 381 | -- |
| | D(mm) | 19 | 25 | 38 | 51 | 76 | -- |
| | H(mm) | 115 | 122 | 125 | 157 | 178 | -- |
| | Do(mm) | 160 | 230 | 230 | 400 | 400 | -- |
| | d(mm) | 13 | 19 | 25 | 38 | 51 | -- |
| WT(kg) | 5.6 | 6.8 | 12.0 | 16.5 | 24.0 | -- | |

General

Trunnion mounted ball valves are designed in accordance with API 6D for classes ASME Class 150,300,600,900,1500,and 2500,Two-piece split body cast steel and Three-piece forged steel side entry design bolted connections between body and closure,trunnion bolted connection, body thickness comply with ANSI B16.34.Seat ring is floating type,springloaded to assure the contact with ball in order to provide an effective tight seal even at low differential pressure between cavity and downstream closure. Standard design is soft seated,Adifferent soft seat materials are available based on the customer working condition.Available in Full and Reduced Bore.Electrical,pneumatic and hydraulic actuators are available based on customer requirement.Valves have been designed for use with various combinations of materials such as:Carbon Steel,Low Carbonsteel, special alloy,stainless steel,Monel,Inconel.

Stem Design/Anti Blowout

The stem is made separately from the ball,anti blow-up design with suitable PTFE and graphite rings, See Fig 1

Anti-Static Device

All flow control-floating flange ball valves include dual grounding systems from stem to ball and stem to body.Valve testing to BS 5351 and BS 5146 wasperformed for all sizes,and witnessed by a third party inspection company.See fig.1

Emergency sealant injection

Trunnion type ball valves are fitted with emergency seals to restore sealing in case of soft seal damage.see fig.1 and fig.2

Double Block and Bleed

Ball valves can be equipped with drain valve which allows the block and bleed feature when the pressure is simultaneously applied to both sides of the ball,the medium can be relieved through the drain valve.Standard design of trunnion mounted ball valves assure that each seat ring performs the "single piston action"

Body Joint Construction

Three pieces body end entry design,graphite ring or o-ring viton(or request)seal ensure absolute seal integrity.The bolted body designs include a tight tolerance overlapping metal fit between the body and the adapter to minimize any possibility of movement due to pipeline stress,High temperature spiral wound stainless seel/grafoil filled gasket is used for absolute seal.Body and adaptors are dimensioned for metal contact to ensure correct gasket crush.

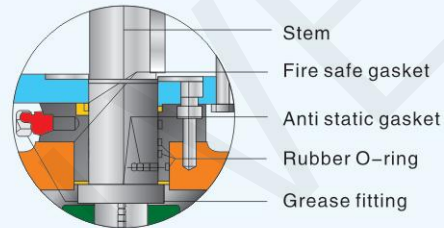

Fig.1



Fig.2

Fig.3 shows pressure $A < A1$.the contact between ball and seat ring assured. Fig.4 shows pressure $B > B1$.the self relieving action allows that valve seat will move slightly away from the ball surface,so any over pressure acting in the body cavity is discharged on the line to restore the balance between the body cavity and line

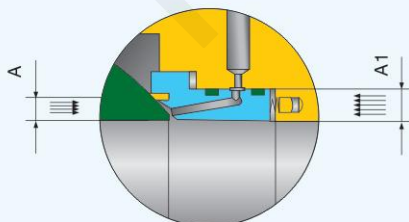

Fig.3

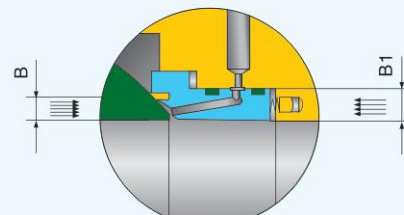

Fig.4

Top Flange

Top flange surface are machined and drilled, ready for mounting actuator.

Fire Safe

All fire-safe valves conform to API 607 and API 6FAstandards.

■ Features Two-piece body

Valve is designed in accordance with the requirements of API 6D for pipeline service. Antistatic and anti blow-out stem design.

Seat design gives perfect tightness and is available as either self-relieving type or double piston effect type.

Design minimizes friction leading to low operating torque.

Available as double block and bleed device, which allows for venting and draining of ling fluid from the body cavity.

Full and Reduced bore Available.

Ball valves fire safe tested according to BS EN 12266-2, API 6FA and API 607.

Electric, pneumatic and hydraulic actuators are available based on customer's requirement.

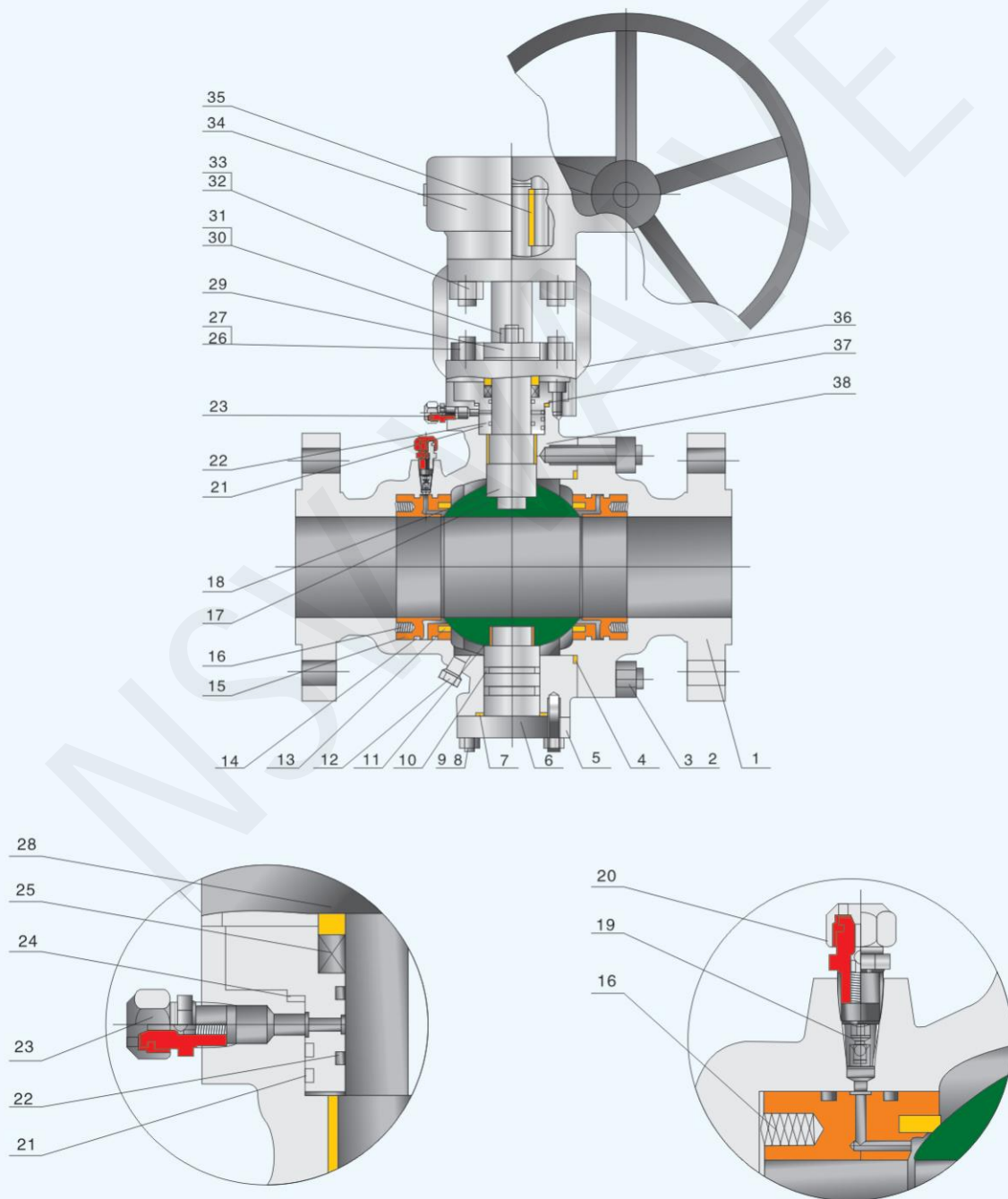

■ **Material Specifications**

| No | Parts | Standard | Stainless Steel | Sour Service | Low Temperature Service |
|----|------------------|-----------------------|-----------------------|-----------------------|-------------------------|
| 1 | Body | ASTM A216 WCB | ASTM A351 CF8M | ASTM A216 WCB | ASTM A352 LCB |
| 2 | Body stud | ASTM A193 B7 | ASTM A193 B8 | ASTM A193 B7M | ASTM A320 L7M |
| 3 | Body Nut | ASTM A194 2H | ASTM A194 8 | ASTM A194 2HM | ASTM A194 7M |
| 4 | Body Gasket | 316ss+Graphite | 316ss+Graphite | 316ss+Graphite | 316ss+Graphite |
| 5 | Low Cover | Carbon Steel | S.S. | Carbon Steel | Carbon Steel |
| 6 | Trunnion Support | ASTM A216 WCB/ENP | ASTM A216 WCB/ENP | ASTM A216 WCB/ENP | ASTM A216 WCB/ENP |
| 7 | Thrust Washer | 316+PTFE+MoS2 | 316+PTFE+MoS2 | 316+PTFE+MoS2 | 316+PTFE+MoS2 |
| 8 | Stud | ASTM A193 B7 | ASTM A193 B8 | ASTM A193 B7M | ASTM A320 L7M |
| 9 | Nut | ASTM A194 2H | ASTM A194 8 | ASTM A194 2HM | ASTM A194 2M |
| 10 | O-Ring | NBR | NBR | NBR | NBR |
| 11 | Bearing | 316+PTFE+MoS2 | 316+PTFE+MoS2 | 316+PTFE+MoS2 | 316+PTFE+MoS2 |
| 12 | Drain Plug | Assembly | Assembly | Assembly | Assembly |
| 13 | Seat Insert | 25% Glass-filled PTFE | 25% Glass-filled PTFE | 25% Glass-filled PTFE | 25% Glass-filled PTFE |
| 14 | O-Ring | NBR | NBR | NBR | NBR |
| 15 | Seat | ASTM A105/ENP | ASTM A182 F316 | ASTM A105/ENP | ASTM A350 LF2/ENP |
| 16 | Seat Spring | Inconel X-750 | Inconel X-750 | Inconel X-750 | Inconel X-750 |
| 17 | Ball | ASTM A 105/ENP | ASTM A182 F316 | ASTM A105/ENP | ASTM A350 LF2/ENP |
| 18 | Stem | ASTM A182 F316 | ASTM A182 F316 | ASTM A182 F316 | ASTM A182 F316 |
| 19 | Seat Injection | Assembly | Assembly | Assembly | Assembly |
| 20 | Sealant Fitting | Assembly | Assembly | Assembly | Assembly |
| 21 | O-Ring | NBR | NBR | NBR | NBR |
| 22 | O-Ring | NBR | NBR | NBR | NBR |
| 23 | Sealant Fitting | Assembly | Assembly | Assembly | Assembly |
| 24 | Gasket | 316ss+Graphite | 316ss+Graphite | 316ss+Graphite | 316ss+Graphite |
| 25 | Packing | Graphite | Graphite | Graphite | Graphite |
| 26 | Stud | ASTM A193 B7 | ASTM A193 B8 | ASTM A193 B7M | ASTM A320 L7M |
| 27 | Nut | ASTM A194 2H | ASTM A194 8 | ASTM A194 2HM | ASTM A194 7M |
| 28 | Gland | ASTM A182 F316 | ASTM A182 F316 | ASTM A182 F316 | ASTM A182 F316 |
| 29 | Gland Flange | ASTM A216 WCB | ASTM A351 CF8M | ASTM A216 WCB | ASTM A352 LCB |
| 30 | Stud | ASTM A193 B7 | ASTM A193 B8 | ASTM A193 B7M | ASTM A320 L7M |
| 31 | Nut | ASTM A 194 2H | ASTM A 194 8 | ASTM A 194 2HM | ASTM A 194 7M |
| 32 | Stud | ASTM A193 B7 | ASTM A193 B8 | ASTM A193 B7M | ASTM A320 L7M |
| 33 | Nut | ASTM A194 2H | ASTM A194 8 | ASTM A194 2HM | ASTM A194 7M |
| 34 | Worm | Assembly | Assembly | Assembly | Assembly |
| 35 | Key | Carbon Steel | S.S. | Carbon Steel | ASTM A182 F304 |
| 36 | Yoke | ASTM A216 WCB | ASTM A351 CF8M | ASTM A216 WCB | ASTM A352 LCB |
| 37 | Bolt | Carbon Steel | S.S. | Carbon Steel | Carbon Steel |
| 38 | Bearing | 316+PTFE+MoS2 | 316+PTFE+MoS2 | 316+PTFE+MoS2 | 316+PTFE+MoS2 |

The body material is also available A351 CF8, CF3,CF3M, duplex stainless steel etc. The trim/seat material can be customized upon request.

Class 150 / JIS10K, Class300 / JIS20K Two-piece, split body, cast steel, side entry design

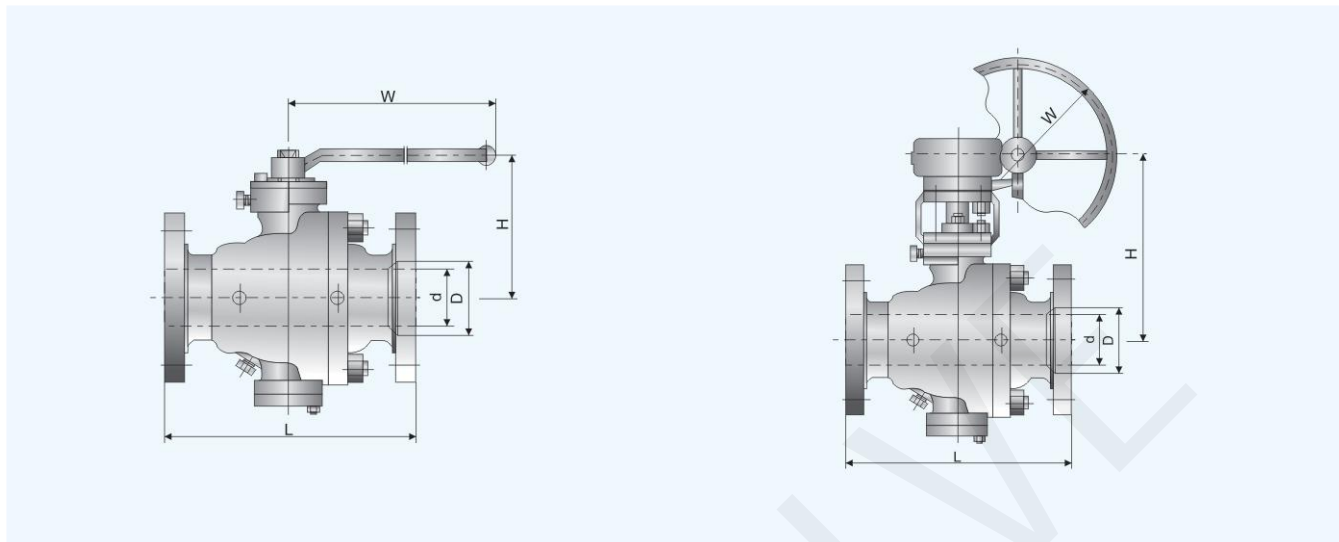

■ **Full bore(Class 150/10K)**

| Size(in) | d(mm) | L(mm) | H(mm) | W(mm) | WT(kg) |
|----------|-------|-------|-------|-------|--------|
| 2 | 51 | 178 | 165 | 230 | 17 |
| 3 | 76 | 203 | 193 | 400 | 33 |
| 4 | 102 | 229 | 231 | 460 | 50 |
| 6 | 152 | 394 | 390 | 1000 | 93 |
| 8 | 203 | 457 | 495 | *500 | 166 |
| 10 | 254 | 533 | 505 | *500 | 273 |
| 12 | 305 | 610 | 560 | *500 | 475 |
| 14 | 337 | 686 | 600 | *500 | 570 |
| 16 | 387 | 762 | 750 | *500 | 778 |
| 18 | 438 | 864 | 845 | *500 | 935 |
| 20 | 489 | 914 | 910 | *500 | 1190 |
| 22 | 540 | 1016 | 1000 | *500 | 1346 |
| 24 | 591 | 1067 | 1065 | *500 | 1579 |

■ **Reduce bore(Class 150/10K)**

| Size(in) | d(mm) | D(mm) | L(mm) | H(mm) | W(mm) | WT(kg) |
|----------|-------|-------|-------|-------|-------|--------|
| 3×2×3 | 51 | 76 | 203 | 165 | 230 | 30 |
| 4×3×4 | 76 | 102 | 229 | 193 | 400 | 47 |
| 6×4×6 | 102 | 152 | 394 | 231 | 400 | 90 |
| 8×6×8 | 152 | 203 | 457 | 390 | 460 | 161 |
| 10×8×10 | 203 | 254 | 533 | 495 | 1000 | 268 |
| 12×10×12 | 254 | 305 | 610 | 505 | *500 | 467 |
| 14×12×14 | 305 | 337 | 686 | 560 | *500 | 560 |
| 16×14×16 | 337 | 387 | 762 | 600 | *500 | 766 |
| 18×16×18 | 387 | 438 | 864 | 750 | *500 | 902 |
| 20×18×20 | 438 | 489 | 914 | 845 | *500 | 1130 |
| 22×20×22 | 489 | 540 | 1016 | 910 | *500 | 1300 |
| 24×22×24 | 540 | 591 | 1067 | 1000 | *500 | 1520 |

■ **Full bore(Class 300/20K)**

| Size(in) | d(mm) | L(mm) | H(mm) | W(mm) | WT(kg) |
|----------|-------|-------|-------|-------|--------|
| 2 | 51 | 216 | 165 | 230 | 18 |
| 3 | 76 | 283 | 193 | 400 | 40 |
| 4 | 102 | 305 | 231 | 750 | 63 |
| 6 | 152 | 403 | 390 | 1000 | 150 |
| 8 | 203 | 502 | 495 | 1500 | 240 |
| 10 | 254 | 568 | 505 | *500 | 305 |
| 12 | 305 | 648 | 560 | *500 | 507 |
| 14 | 337 | 762 | 600 | *500 | 602 |
| 16 | 387 | 838 | 750 | *500 | 1000 |
| 18 | 438 | 914 | 845 | *500 | 1160 |
| 20 | 489 | 991 | 910 | *500 | 1320 |
| 22 | 540 | 1092 | 1000 | *500 | 1540 |
| 24 | 591 | 1143 | 1065 | *500 | 1874 |

■ **Reduce bore(Class 300/20K)**

| Size(in) | d(mm) | D(mm) | L(mm) | H(mm) | W(mm) | WT(kg) |
|----------|-------|-------|-------|-------|-------|--------|
| 3×2×3 | 51 | 76 | 283 | 165 | 230 | 38 |
| 4×3×4 | 76 | 102 | 305 | 193 | 400 | 60 |
| 6×4×6 | 102 | 152 | 403 | 231 | 750 | 147 |
| 8×6×8 | 152 | 203 | 502 | 390 | 1000 | 234 |
| 10×8×10 | 203 | 254 | 568 | 495 | 1500 | 295 |
| 12×10×12 | 254 | 305 | 648 | 505 | *500 | 488 |
| 14×12×14 | 305 | 337 | 762 | 560 | *500 | 570 |
| 16×14×16 | 337 | 387 | 838 | 600 | *500 | 910 |
| 18×16×18 | 387 | 438 | 914 | 750 | *500 | 1020 |
| 20×18×20 | 438 | 489 | 991 | 845 | *500 | 1280 |
| 22×20×22 | 489 | 540 | 1092 | 910 | *500 | 1360 |
| 24×22×24 | 540 | 591 | 1143 | 1000 | *500 | 1670 |

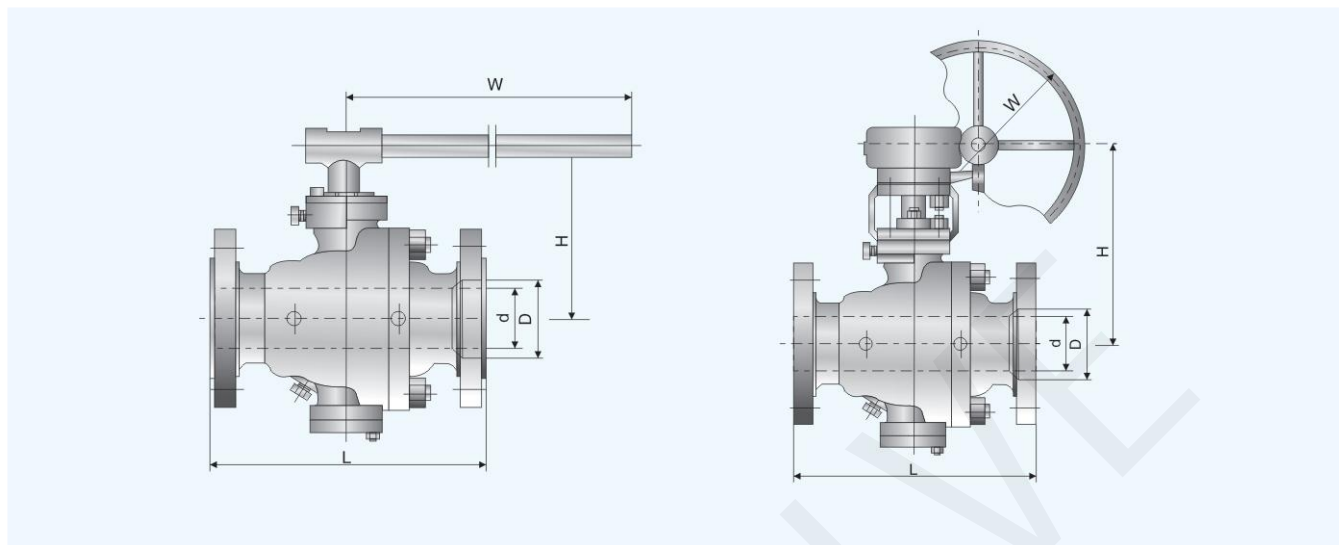

■ **Full bore(Class 600)**

| Size(in) | d(mm) | L(mm) | H(mm) | W(mm) | WT(kg) |
|----------|-------|-------|-------|-------|--------|
| 2 | 51 | 292 | 176 | 400 | 27 |
| 3 | 76 | 356 | 247 | 750 | 50 |
| 4 | 102 | 432 | 335 | 1000 | 80 |
| 6 | 152 | 559 | 420 | 1500 | 220 |
| 8 | 203 | 660 | 430 | *500 | 350 |
| 10 | 254 | 787 | 520 | *500 | 600 |
| 12 | 305 | 838 | 665 | *500 | 820 |
| 14 | 337 | 889 | 720 | *500 | 1130 |
| 16 | 387 | 991 | 780 | *500 | 1550 |
| 18 | 438 | 1092 | 950 | *500 | 2100 |
| 20 | 489 | 1194 | 1010 | *500 | 2800 |
| 24 | 591 | 1397 | 1120 | *500 | 3626 |

■ **Reduce bore(Class 600)**

| Size(in) | d(mm) | D(mm) | L(mm) | H(mm) | W(mm) | WT(kg) |
|--------------|-------|-------|-------|-------|-------|--------|
| 3 × 2 × 3 | 51 | 76 | 356 | 176 | 400 | 41 |
| 4 × 3 × 4 | 76 | 102 | 432 | 247 | 750 | 70 |
| 6 × 4 × 6 | 102 | 152 | 559 | 335 | 1000 | 122 |
| 8 × 6 × 8 | 152 | 203 | 660 | 420 | 1500 | 255 |
| 10 × 8 × 10 | 203 | 254 | 787 | 430 | *500 | 440 |
| 12 × 10 × 12 | 254 | 305 | 838 | 520 | *500 | 662 |
| 14 × 12 × 14 | 305 | 337 | 889 | 665 | *500 | 1060 |
| 16 × 14 × 16 | 337 | 387 | 991 | 720 | *500 | 1440 |
| 18 × 16 × 18 | 387 | 438 | 1092 | 780 | *500 | 1860 |
| 20 × 18 × 20 | 438 | 489 | 1194 | 950 | *500 | 2400 |
| 24 × 22 × 24 | 489 | 591 | 1397 | 1010 | *500 | 3240 |

■ **Full bore(Class 900)**

| Size(in.) | d(mm) | L(mm) | H(mm) | W(mm) | WT(kg) |
|-----------|-------|-------|-------|-------|--------|
| 2 | 51 | 368 | 192 | 460 | 52 |
| 3 | 76 | 381 | 279 | 1000 | 97 |
| 4 | 102 | 457 | 355 | 1500 | 138 |
| 6 | 152 | 610 | 385 | *500 | 288 |
| 8 | 203 | 737 | 460 | *500 | 448 |
| 10 | 254 | 838 | 600 | *500 | 748 |
| 12 | 305 | 965 | 690 | *500 | 1018 |
| 14 | 324 | 1029 | 785 | *500 | 1398 |
| 16 | 375 | 1130 | 850 | *500 | 1828 |
| 18 | 426 | 1219 | 915 | *500 | 2328 |
| 20 | 473 | 1321 | 975 | *610 | 2928 |
| 24 | 572 | 1549 | 1030 | *610 | 4178 |

■ **Reduce bore(Class 900)**

| Size(in) | d(mm) | D(mm) | L(mm) | H(mm) | W(mm) | WT(kg) |
|--------------|-------|-------|-------|-------|-------|--------|
| 3 × 2 × 3 | 51 | 76 | 381 | 192 | 460 | 83 |
| 4 × 3 × 4 | 76 | 102 | 457 | 279 | 1000 | 103 |
| 6 × 4 × 6 | 102 | 152 | 610 | 355 | 1500 | 201 |
| 8 × 6 × 8 | 152 | 203 | 737 | 385 | *500 | 348 |
| 10 × 8 × 10 | 203 | 254 | 838 | 460 | *500 | 598 |
| 12 × 10 × 12 | 254 | 305 | 965 | 600 | *500 | 788 |
| 14 × 12 × 14 | 305 | 324 | 1029 | 690 | *500 | 1100 |
| 16 × 14 × 16 | 324 | 375 | 1130 | 785 | *500 | 1420 |
| 18 × 16 × 18 | 375 | 426 | 1219 | 850 | *500 | 1928 |
| 20 × 18 × 20 | 426 | 473 | 1321 | 915 | *500 | 2428 |
| 24 × 22 × 24 | 473 | 572 | 1549 | 975 | 610 | 3578 |

Three-piece, split body, forged steel, side entry design



■ Features Three-piece body

- Valve is designed in accordance with the requirements of API 6D for pipeline service.
- Antistatic and anti blow-out stem design.
- Seat design gives perfect tightness and is available as either self-relieving type or double piston effect type.
- Design minimizes friction leading to low operating torque.
- Available as double block and bleed device, which allows for venting and draining of line fluid from the body cavity.
- Full and Reduced bore Available.
- Ball valves fire safe tested according to BS EN 12266-2, API 6FA and API 607.
- Electric, pneumatic and hydraulic actuators are available based on customer's requirement.

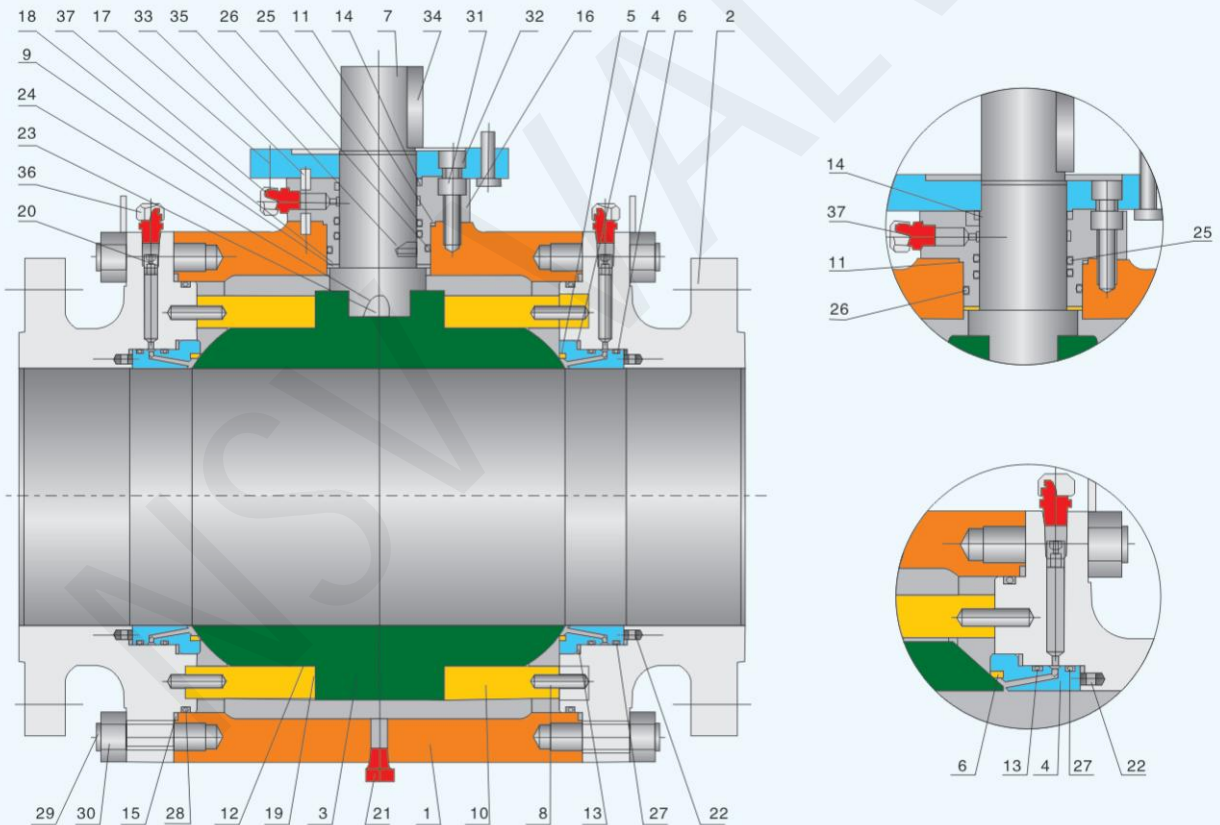

■ **Material List**

| No | Parts | Standard | Stainless Steel | Sour Service | Low Temperature Service |
|----|------------------------|-----------------------|-----------------------|-----------------------|-------------------------|
| 1 | Body | ASTM A105 | ASTM A182 F316 | ASTM A105 | ASTM A350 LF2 |
| 2 | Closure | ASTM A105 | ASTM A182 F316 | ASTM A105 | ASTM A350 LF2 |
| 3 | Ball | ASTM A105/ENP | ASTM A182 F316 | ASTM A105/ENP | A350 LF2/ENP |
| 4 | Seat Assembly | Assembled | Assembly | Assembled | Assembled |
| 5 | Seat Insert | 25% Glass-filled PTFE | 25% Glass-filled PTFE | 25% Glass-filled PTFE | 25% Glass-filled PTFE |
| 6 | Seat Ring | ASTM A105/ENP | ASTM A182 F316 | ASTM A105/ENP | A350 LF2/ENP |
| 7 | Stem | ASTM A182 F6a | ASTM A182 F316 | ASTM A182 F316 | ASTM A182 F316 |
| 8 | Trunnion Alignment Pin | ASTM A182 F316 | ASTM A182 F316 | ASTM A182 F316 | ASTM A182 F316 |
| 9 | Shim | ASTM A182 F316 | ASTM A182 F316 | ASTM A182 F316 | ASTM A182 F316 |
| 10 | Trunnion Support | ASTM A105/ENP | ASTM A182 F316 | ASTM A105/ENP | A350 LF2/ENP |
| 11 | Gasket | 316 S.S.+Graphite | 316 S.S.+Graphite | 316 S.S.+Graphite | 316 S.S.+Graphite |
| 12 | Gasket | 316 S.S.+Graphite | 316 S.S.+Graphite | 316 S.S.+Graphite | 316 S.S.+Graphite |
| 13 | Gasket | 316 S.S.+Graphite | 316 S.S.+Graphite | 316 S.S.+Graphite | 316 S.S.+Graphite |
| 14 | Spacer | PTFE | PTFE | PTFE | PTFE |
| 15 | Firesafe Gasket | 316 S.S.+Graphite | 316 S.S.+Graphite | 316 S.S.+Graphite | 316 S.S.+Graphite |
| 16 | Gland Cap | ASTM A 105 | ASTM A 182 F316 | ASTM A 105 | ASTM A 350 LF2 |
| 17 | Top Flange | ASTM A 105 | ASTM A 182 F316 | ASTM A 105 | ASTM A 350 LF2 |
| 18 | Thrust Washer | 316 S.S.+PTFE+MoS2 | 316 S.S.+PTFE+MoS2 | 316 S.S.+PTFE+MoS2 | 316 S.S.+PTFE+MoS2 |
| 19 | Bearing | 316 S.S.+PTFE+MoS2 | 316 S.S.+PTFE+MoS2 | 316 S.S.+PTFE+MoS2 | 316 S.S.+PTFE+MoS2 |
| 20 | Vent Valve | Assembly | Assembly | Assembly | Assembly |
| 21 | Drain | S.S. | S.S. | S.S. | S.S. |
| 22 | Seat Spring | Inconel X-750 | Inconel X-750 | Inconel X-750 | Inconel X-750 |
| 23 | Grounding Spring | S.S. | S.S. | S.S. | S.S. |
| 24 | Grounding Plunger | ASTM A 182 F316 | ASTM A 182 F316 | ASTM A 182 F316 | ASTM A 182 F316 |
| 25 | O-Ring | Viton | Viton | Viton | Viton |
| 26 | O-Ring | Viton | Viton | Viton | Viton |
| 27 | O-Ring | Viton | Viton | Viton | Viton |
| 28 | O-Ring | Viton | Viton | Viton | Viton |
| 29 | Body Stud | ASTM A193 B7 | ASTM A193 B8 | ASTM A193 B7M | ASTM A320 L7M |
| 30 | Body Nut | ASTM A194 2H | ASTM A194 8 | ASTM A194 2HM | ASTM A194 7M |
| 31 | Screw | C.S. | S.S. | C.S. | ASTM A320 L7M |
| 32 | Screw | C.S. | S.S. | C.S. | ASTM A320 L7M |
| 33 | Gland Pin | C.S. | S.S. | C.S. | Carbon Steel |
| 34 | Key | C.S. | S.S. | C.S. | ASTM A182 L304 |
| 35 | Spring Pin | C.S. | S.S. | C.S. | C.S. |
| 36 | Seat Injection | Assembly | Assembly | Assembly | Assembly |
| 37 | Stem Injection | Assembly | Assembly | Assembly | Assembly |

The body material is also available A182 F304, F304L, F316L, F51, F53 etc. The trim/seat material can be customized upon request.

Class 150 / JIS10K Three-piece, split body, forged steel, side entry design

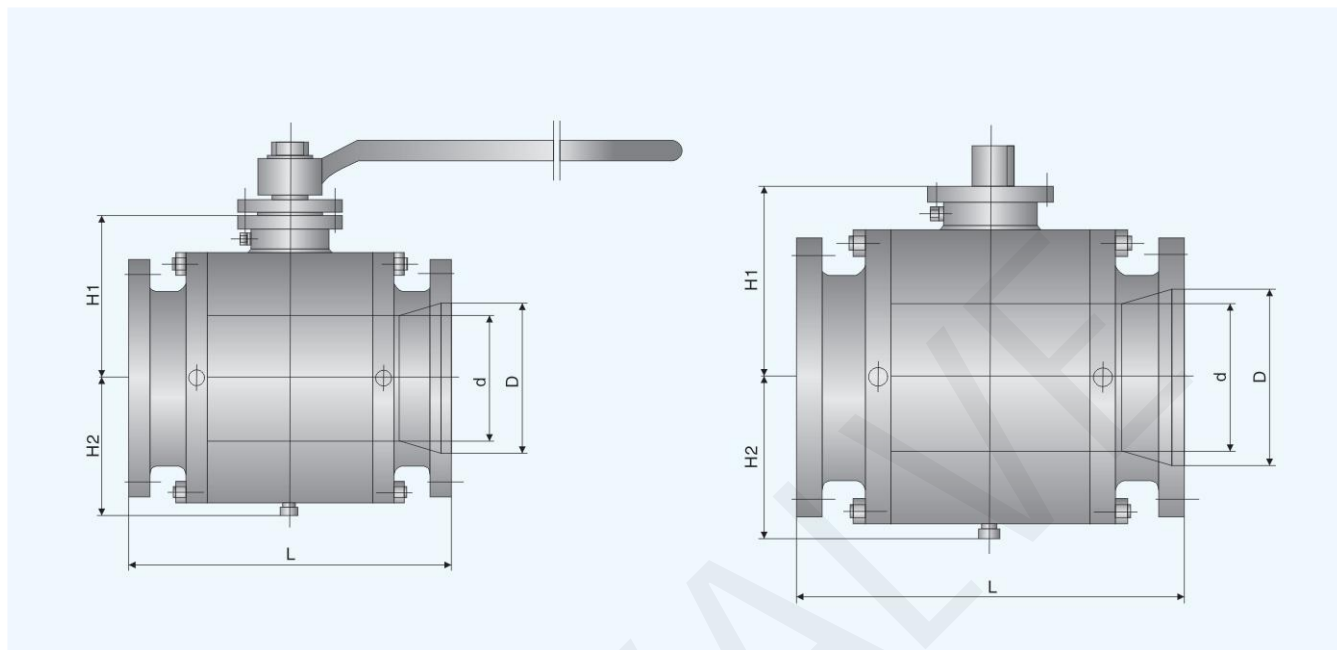

■ **Full Port(Class 150/10K)**

| Size(in) | d(mm) | L(mm) | H1(mm) | H2(mm) | WT(kg) |
|----------|-------|-------|--------|--------|--------|
| 2 | 51 | 178 | 105 | 100 | 32 |
| 3 | 76 | 203 | 160 | 130 | 53 |
| 4 | 102 | 229 | 205 | 170 | 100 |
| 6 | 152 | 394 | 245 | 190 | 157 |
| 8 | 203 | 457 | 280 | 230 | 250 |
| 10 | 254 | 533 | 326 | 280 | 390 |
| 12 | 305 | 610 | 350 | 300 | 578 |
| 14 | 337 | 686 | 380 | 330 | 770 |
| 16 | 387 | 762 | 415 | 350 | 1100 |
| 18 | 438 | 864 | 440 | 400 | 1250 |
| 20 | 489 | 914 | 500 | 440 | 1800 |
| 22 | 540 | 991 | 520 | 470 | 2400 |
| 24 | 591 | 1067 | 585 | 530 | 3100 |
| 26 | 635 | 1143 | 630 | 570 | 3700 |
| 28 | 686 | 1244 | 645 | 650 | 4500 |
| 30 | 736 | 1295 | 700 | 700 | 5300 |
| 32 | 781 | 1371 | 740 | 750 | 6900 |
| 34 | 832 | 1473 | 770 | 780 | 8200 |
| 36 | 876 | 1524 | 820 | 800 | 9700 |
| 40 | 978 | 1753 | 900 | 900 | 13000 |
| 42 | 1022 | 1855 | 960 | 950 | 15000 |
| 48 | 1168 | 2134 | 1100 | 1100 | 23000 |

■ **Reduced Port(Class 150/10K)**

| Size(in) | d(mm) | D(mm) | L(mm) | H1(mm) | H2(mm) | WT(kg) |
|--------------|-------|-------|-------|--------|--------|--------|
| 3 × 2 × 3 | 51 | 76 | 203 | 105 | 100 | 36 |
| 4 × 3 × 4 | 76 | 102 | 229 | 160 | 130 | 63 |
| 6 × 4 × 6 | 102 | 152 | 394 | 205 | 170 | 105 |
| 8 × 6 × 8 | 152 | 203 | 457 | 245 | 190 | 200 |
| 10 × 8 × 10 | 203 | 254 | 533 | 280 | 230 | 300 |
| 12 × 10 × 12 | 254 | 305 | 610 | 326 | 280 | 470 |
| 14 × 10 × 14 | 254 | 337 | 686 | 320 | 280 | 530 |
| 14 × 12 × 14 | 305 | 337 | 686 | 350 | 300 | 630 |
| 16 × 12 × 16 | 305 | 387 | 762 | 350 | 300 | 700 |
| 16 × 14 × 16 | 337 | 387 | 762 | 380 | 330 | 830 |
| 18 × 16 × 18 | 387 | 438 | 864 | 415 | 350 | 1100 |
| 20 × 16 × 20 | 387 | 489 | 914 | 415 | 350 | 1200 |
| 22 × 18 × 22 | 438 | 489 | 914 | 440 | 400 | 1300 |
| 24 × 20 × 24 | 489 | 591 | 1067 | 500 | 440 | 2100 |
| 30 × 24 × 30 | 635 | 736 | 1295 | 585 | 530 | 3400 |
| 36 × 30 × 36 | 781 | 876 | 1524 | 700 | 700 | 6400 |

■ **Notes**

1. Face-to-Face dimensions are according to API 6D
2. For 2" to 24" flanges are according to ASME B16.5
3. For over 24" flanges are according to ASME B16.47 series A.

■ **Full Port(Class 300/20K)**

| Size(in) | d(mm) | L(mm) | H1(mm) | H2(mm) | WT(kg) |
|----------|-------|-------|--------|--------|--------|
| 2 | 51 | 216 | 105 | 100 | 31 |
| 3 | 76 | 282 | 160 | 130 | 58 |
| 4 | 102 | 305 | 205 | 170 | 110 |
| 6 | 152 | 403 | 245 | 190 | 180 |
| 8 | 203 | 502 | 280 | 230 | 280 |
| 10 | 254 | 568 | 326 | 280 | 410 |
| 12 | 305 | 648 | 350 | 300 | 760 |
| 14 | 337 | 762 | 380 | 330 | 1100 |
| 16 | 387 | 838 | 415 | 350 | 1600 |
| 18 | 438 | 914 | 440 | 400 | 1700 |
| 20 | 489 | 991 | 500 | 440 | 2300 |
| 22 | 540 | 1092 | 520 | 470 | 2900 |
| 24 | 591 | 1143 | 585 | 530 | 3500 |
| 26 | 635 | 1245 | 630 | 570 | 4900 |
| 28 | 686 | 1346 | 645 | 650 | 6000 |
| 30 | 736 | 1397 | 700 | 700 | 6800 |
| 32 | 781 | 1524 | 740 | 750 | 8000 |
| 34 | 832 | 1626 | 770 | 780 | 9100 |
| 36 | 876 | 1727 | 820 | 800 | 11000 |
| 40 | 978 | 1956 | 900 | 900 | 14000 |
| 42 | 1022 | 2083 | 960 | 950 | 17000 |
| 48 | 1168 | 2170 | 1100 | 1100 | 25000 |

■ **Reduced Port(Class 300/20K)**

| Size(in) | d(mm) | D(mm) | L(mm) | H1(mm) | H2(mm) | WT(kg) |
|--------------|-------|-------|-------|--------|--------|--------|
| 3 × 2 × 3 | 51 | 76 | 283 | 105 | 100 | 34 |
| 4 × 3 × 4 | 76 | 102 | 305 | 160 | 130 | 70 |
| 6 × 4 × 6 | 102 | 152 | 403 | 205 | 170 | 120 |
| 8 × 6 × 8 | 152 | 203 | 502 | 245 | 190 | 220 |
| 10 × 8 × 10 | 203 | 254 | 568 | 280 | 230 | 320 |
| 12 × 10 × 12 | 254 | 305 | 648 | 326 | 280 | 600 |
| 14 × 10 × 14 | 254 | 337 | 762 | 320 | 280 | 660 |
| 14 × 12 × 14 | 305 | 337 | 762 | 350 | 300 | 850 |
| 16 × 12 × 16 | 305 | 387 | 838 | 350 | 300 | 1000 |
| 16 × 14 × 16 | 337 | 387 | 838 | 380 | 330 | 1200 |
| 18 × 16 × 18 | 387 | 438 | 914 | 415 | 350 | 1700 |
| 20 × 16 × 20 | 387 | 489 | 991 | 415 | 350 | 1700 |
| 22 × 18 × 22 | 438 | 489 | 991 | 440 | 400 | 1850 |
| 24 × 20 × 24 | 489 | 591 | 1143 | 500 | 440 | 2700 |
| 30 × 24 × 30 | 591 | 736 | 1397 | 585 | 530 | 4600 |
| 36 × 30 × 36 | 736 | 876 | 1727 | 700 | 700 | 8000 |

■ **Notes**

- 1.Face-to-Face dimensions are according to API 6D
- 2.For 2" to 24" flanges are according to ASME B16.5
- 3.For over 24" flanges are according to ASME B16.47 series A.

■ **Full Port(Class 600)**

| Size(in) | d(mm) | L(mm) | H1(mm) | H2(mm) | WT(kg) |
|----------|-------|-------|--------|--------|--------|
| 2 | 51 | 292 | 105 | 100 | 35 |
| 3 | 76 | 356 | 160 | 130 | 66 |
| 4 | 102 | 432 | 205 | 170 | 118 |
| 6 | 152 | 559 | 245 | 190 | 270 |
| 8 | 203 | 660 | 280 | 230 | 500 |
| 10 | 254 | 787 | 326 | 280 | 780 |
| 12 | 305 | 838 | 350 | 300 | 1100 |
| 14 | 337 | 889 | 380 | 330 | 1100 |
| 16 | 387 | 991 | 415 | 350 | 1600 |
| 18 | 438 | 1092 | 440 | 400 | 2160 |
| 20 | 489 | 1194 | 500 | 440 | 2700 |
| 22 | 540 | 1296 | 520 | 470 | 3900 |
| 24 | 591 | 1397 | 585 | 530 | 5000 |
| 26 | 635 | 1448 | 630 | 570 | 5700 |
| 28 | 686 | 1549 | 645 | 650 | 7000 |
| 30 | 736 | 1651 | 700 | 700 | 9000 |
| 32 | 781 | 1778 | 740 | 750 | 9800 |
| 34 | 832 | 1930 | 770 | 780 | 12000 |
| 36 | 876 | 2083 | 820 | 800 | 14000 |
| 40 | 978 | 2337 | 900 | 900 | 19000 |
| 42 | 1022 | 2437 | 960 | 950 | 22000 |
| 48 | 1168 | 2540 | 1100 | 1100 | 26000 |

■ **Reduced Port(Class 600)**

| Size(in) | d(mm) | D(mm) | L(mm) | H1(mm) | H2(mm) | WT(kg) |
|--------------|-------|-------|-------|--------|--------|--------|
| 3 × 2 × 3 | 51 | 76 | 356 | 105 | 100 | 42 |
| 4 × 3 × 4 | 76 | 102 | 432 | 160 | 130 | 90 |
| 6 × 4 × 6 | 102 | 152 | 559 | 205 | 170 | 160 |
| 8 × 6 × 8 | 152 | 203 | 660 | 245 | 190 | 300 |
| 10 × 8 × 10 | 203 | 254 | 787 | 280 | 230 | 560 |
| 12 × 10 × 12 | 254 | 305 | 838 | 326 | 280 | 820 |
| 14 × 10 × 14 | 254 | 337 | 889 | 320 | 280 | 920 |
| 14 × 12 × 14 | 305 | 337 | 889 | 350 | 300 | 1200 |
| 16 × 12 × 16 | 305 | 387 | 991 | 350 | 300 | 1400 |
| 16 × 14 × 16 | 337 | 387 | 991 | 380 | 330 | 1400 |
| 18 × 16 × 18 | 387 | 438 | 1092 | 415 | 350 | 1700 |
| 20 × 16 × 20 | 387 | 489 | 1194 | 415 | 350 | 2100 |
| 22 × 18 × 22 | 438 | 489 | 1194 | 440 | 400 | 2400 |
| 24 × 20 × 24 | 489 | 591 | 1397 | 500 | 440 | 3300 |
| 30 × 24 × 30 | 591 | 736 | 1651 | 585 | 530 | 5900 |
| 36 × 30 × 36 | 736 | 876 | 2083 | 700 | 700 | 11000 |

■ **Notes**

- 1.Face-to-Face dimensions are according to API 6D
- 2.For 2" to 24" flanges are according to ASME B16.5
- 3.For over 24" flanges are according to ASME B16.47 series A.

Class 900 / 1500 / 2500 Three-piece, split body, forged steel, side entry design



Full Port(Class 900)

| Size(in) | d(mm) | L(mm) | H1(mm) | H2(mm) | WT(kg) |
|----------|-------|-------|--------|--------|--------|
| 2 | 51 | 368 | 105 | 100 | 50 |
| 3 | 76 | 381 | 160 | 130 | 80 |
| 4 | 102 | 457 | 205 | 170 | 150 |
| 6 | 152 | 610 | 245 | 190 | 360 |
| 8 | 203 | 737 | 280 | 230 | 620 |
| 10 | 254 | 838 | 326 | 280 | 1100 |
| 12 | 305 | 965 | 350 | 300 | 1600 |
| 14 | 324 | 1029 | 380 | 330 | 1450 |
| 16 | 375 | 1130 | 415 | 350 | 2200 |
| 18 | 425 | 1219 | 440 | 400 | 2800 |
| 20 | 473 | 1321 | 500 | 440 | 4250 |
| 22 | 524 | 1422 | 520 | 470 | 6500 |
| 24 | 572 | 1549 | 585 | 530 | 7000 |
| 26 | 669 | 1651 | 630 | 570 | 8000 |
| 28 | 667 | 1753 | 645 | 650 | 9500 |
| 30 | 714 | 1880 | 700 | 700 | 12500 |
| 32 | 762 | 2032 | 740 | 750 | 12000 |
| 34 | 808 | 2159 | 770 | 780 | 18000 |

Reduced Port(Class 900)

| Size(in) | d(mm) | D(mm) | L(mm) | H1(mm) | H2(mm) | WT(kg) |
|--------------|-------|-------|-------|--------|--------|--------|
| 3 × 2 × 3 | 51 | 76 | 381 | 105 | 100 | 55 |
| 4 × 3 × 4 | 76 | 102 | 457 | 160 | 130 | 100 |
| 6 × 4 × 6 | 102 | 152 | 610 | 205 | 170 | 220 |
| 8 × 6 × 8 | 152 | 203 | 737 | 245 | 190 | 450 |
| 10 × 8 × 10 | 203 | 254 | 838 | 280 | 230 | 560 |
| 12 × 10 × 12 | 254 | 305 | 965 | 326 | 280 | 820 |
| 14 × 10 × 14 | 254 | 337 | 1029 | 320 | 280 | 920 |
| 14 × 12 × 14 | 305 | 337 | 1029 | 350 | 300 | 1200 |
| 16 × 12 × 16 | 305 | 387 | 1130 | 350 | 300 | 1400 |
| 16 × 14 × 16 | 324 | 387 | 1130 | 380 | 330 | 1400 |
| 18 × 16 × 18 | 375 | 438 | 1219 | 415 | 350 | 1700 |
| 20 × 16 × 20 | 375 | 489 | 1321 | 415 | 350 | 2100 |
| 22 × 18 × 22 | 425 | 489 | 1321 | 440 | 400 | 2400 |
| 24 × 20 × 24 | 473 | 591 | 1549 | 500 | 440 | 3300 |
| 30 × 24 × 30 | 572 | 736 | 1880 | 585 | 530 | 5900 |
| 36 × 30 × 36 | 714 | 876 | 2286 | 700 | 700 | 11000 |

- Notes:
 1.Face-to-Face dimensions are according to API 6D
 2.For 2" to 24" flanges are according to ASME B16.5
 3.For over 24" flanges are according to ASME B16.47 series A.

Full Port(Class 1500)

| Size(in) | d(mm) | L(mm) | H1(mm) | H2(mm) | WT(kg) |
|----------|-------|-------|--------|--------|--------|
| 2 | 51 | 368 | 110 | 105 | 60 |
| 3 | 76 | 470 | 165 | 130 | 100 |
| 4 | 102 | 546 | 220 | 170 | 210 |
| 6 | 146 | 705 | 260 | 230 | 500 |
| 8 | 194 | 832 | 310 | 290 | 850 |
| 10 | 241 | 991 | 370 | 360 | 1600 |
| 12 | 289 | 1130 | 430 | 440 | 2300 |
| 14 | 317 | 1257 | 450 | 450 | 2950 |
| 16 | 362 | 1384 | 500 | 600 | 4200 |

Reduced Port(Class 1500)

| Size(in) | d(mm) | D(mm) | L(mm) | H1(mm) | H2(mm) | WT(kg) |
|--------------|-------|-------|-------|--------|--------|--------|
| 3 × 2 × 3 | 51 | 76 | 470 | 110 | 105 | 70 |
| 4 × 3 × 4 | 76 | 102 | 546 | 165 | 130 | 130 |
| 6 × 4 × 6 | 102 | 146 | 705 | 220 | 170 | 300 |
| 8 × 6 × 8 | 146 | 194 | 832 | 260 | 230 | 580 |
| 10 × 8 × 10 | 194 | 241 | 991 | 310 | 290 | 1100 |
| 12 × 10 × 12 | 241 | 289 | 1130 | 370 | 360 | 1800 |
| 14 × 10 × 14 | 241 | 317 | 1257 | 370 | 360 | 2200 |
| 14 × 12 × 14 | 289 | 317 | 1257 | 430 | 440 | 2600 |
| 16 × 12 × 16 | 289 | 362 | 1384 | 430 | 440 | 2900 |
| 16 × 14 × 16 | 317 | 362 | 1384 | 450 | 450 | 3300 |
| 18 × 16 × 18 | 362 | 407 | 1537 | 500 | 600 | 500 |
| 20 × 16 × 20 | 362 | 457 | 1664 | 500 | 600 | 5600 |

Full Port(Class 2500)

| Size(in) | d(mm) | L(mm) | H1(mm) | H2(mm) | WT(kg) |
|----------|-------|-------|--------|--------|--------|
| 2 | 44.5 | 451 | 120 | 130 | 100 |
| 3 | 63.5 | 578 | 180 | 200 | 200 |
| 4 | 89 | 673 | 230 | 250 | 390 |
| 6 | 133 | 914 | 260 | 250 | 790 |
| 8 | 181 | 1022 | 400 | 350 | 1400 |
| 10 | 226 | 1270 | 450 | 420 | 2200 |
| 12 | 267 | 1422 | 520 | 510 | 3400 |

Reduced Port(Class 2500)

| Size(in) | d(mm) | D(mm) | L(mm) | H1(mm) | H2(mm) | WT(kg) |
|--------------|-------|-------|-------|--------|--------|--------|
| 3 × 2 × 3 | 44.5 | 63.5 | 578 | 120 | 130 | 170 |
| 4 × 3 × 4 | 63.5 | 89 | 673 | 180 | 200 | 280 |
| 6 × 4 × 6 | 89 | 133 | 914 | 260 | 250 | 520 |
| 8 × 6 × 8 | 133 | 181 | 1022 | 400 | 250 | 1100 |
| 10 × 8 × 10 | 181 | 226 | 1270 | 450 | 350 | 1700 |
| 12 × 10 × 12 | 226 | 267 | 1422 | 450 | 420 | 2600 |

Notes

- 1.Face-to-Face dimensions are according to API 6D
 2.For 2" to 24" flanges are according to ASME B16.5

■ General

Metal seated ball valves is particularly applicable in severe service conditions such as granule medium, pasty stock, coom, lime-ash, and of advantage such as reliable sealing capacity and low operation torque value.

■ Utilize advanced technique of ball and seat hardening

Many techniques has been applied in ball and seat hardening such as including supersonic spraying, nimonc alloy spraying-weld, surface peculiarly hardening, carbide spraying-weld and high strength high hardness ceramic materials etc, the hardness of ball and seat can generally reach HRC 62 above, even surpass HRC 70. Refractory of sealing material can generally reach 540 centigrade, and 980 centigrade at its highest. Materials bond-strength can reach 10000PSI or above, Sealing material jiss also of the capability of braze-proof and impact-proof.

■ High capability of seal

With peculiar lapping crafts for the ball, spinning the ball to the lapping appliance from different directions to make the ball surface reach sky-high circularity and cleanliness. the sealing capacity of valve can fully reach or surpass the requirement of standard

■ Moveable seat design

Achieves Zero leakage sealing in bi-directional flow and pressure relief for over-pressure protecting.

■ High temperature warming design

Cup spring supported S.S. ball Seats are of high hardness HV 1500 due to special surface treatment. cup spring made of Inconel alloy can self-compensate the thermal expansion caused by high temperature medium.

■ Fully fire safe design structure

Metal to Metal sealing structure in the sealing surface, and flexible graphite as packing. Stainless steel+flexible graphite as gasket, so when if fire burns up the valve can be sealed properly.

Class 150 / JIS10K, Class 300 / JIS20K, Class 600 Two-piece, split body, side entry design

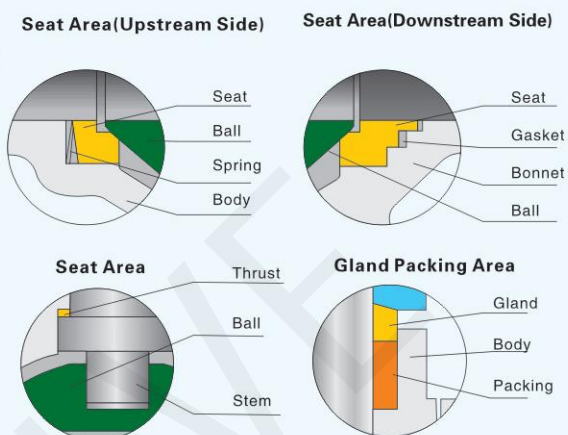
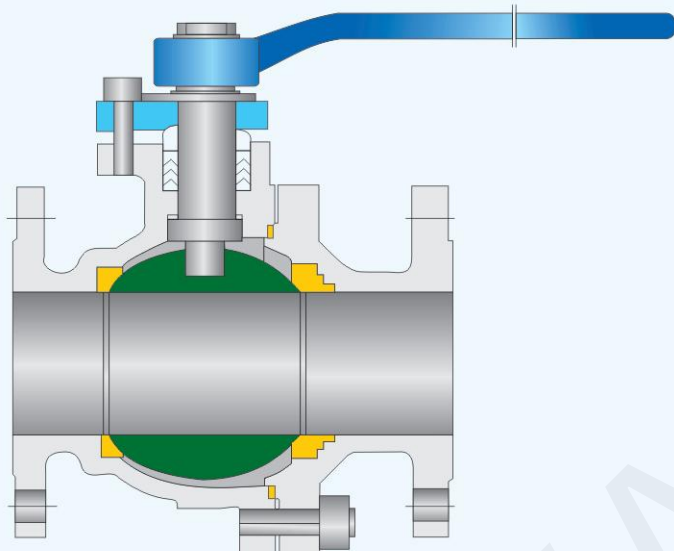

Design features

Design Standards: API 608, BS 5351, JIS B2071, B2081
 Face to face dimension: ASME B16.10, JIS B2002
 Flanged End: ASME B16.5, JIS B2212, B2214
 Testing and inspection: API 598, JIS B2003
 Pressure-Temperature Rating: JIS B2071, B2081

Material List

| Item | Carbon Steel | | Stainless Steel | |
|------------------|----------------------------|-------------------|----------------------------|-------------------|
| | -29°C~250°C | 250°C~425°C | -29°C~250°C | 250°C~550°C |
| Body | ASTM A216 Gr.WCB | | ASTM A351 CF8M | |
| Ball | ASTM A 182 F304+TSC or STL | | ASTM A 182 F316+TSC or STL | |
| Stem | ASTM A182 F6a | | ASTM A182 F316 | |
| Seat | ASTM A 182 F316+TSC or STL | | ASTM A 182 F316+TSC or STL | |
| Gasket | PEEK | Graphite+304 S.S. | PEEK | Graphite+316 S.S. |
| Gland Packing | PEEK | Graphite+304 S.S. | PEEK | Graphite+316 S.S. |
| Stem Bearing | PEEK | Graphite+304 S.S. | PEEK | Graphite+316 S.S. |
| Spring | 17-7PH | Inconel x-750 | 316 Stainless Steel | Inconel x-750 |
| Bolt | ASTM A 193 B7 | | ASTM A 193 B8M | |
| Nut | ASTM A 194 2H | | ASTM A 194 8M | |
| Seat Seal Gasket | Graphite+304 S.S. | | Graphite+316 S.S. | |

Applications of metal seated ball valve

| Type | Size | Temperature Range | Auxiliary Seal | Ball/Seats Seal | Working Condition |
|---------------------|--|-------------------|----------------|--|---|
| Floating Ball Valve | Pressure Class: 150, 300, 600 NPS: 1/2" ~ 8" | -50°C~250°C | PEEK | Ball: nitriding or Nickel base/Co base alloy overlay Seat: Stellite | 1. finishing mixture 2. solid containing fluids 3. high temperature and high pressure |
| | | -50°C~380°C | Graphite | | |
| | | -35°C~550°C | Graphite | Ball: Nickel base/Co base alloy overlay Seat: Stellite | |

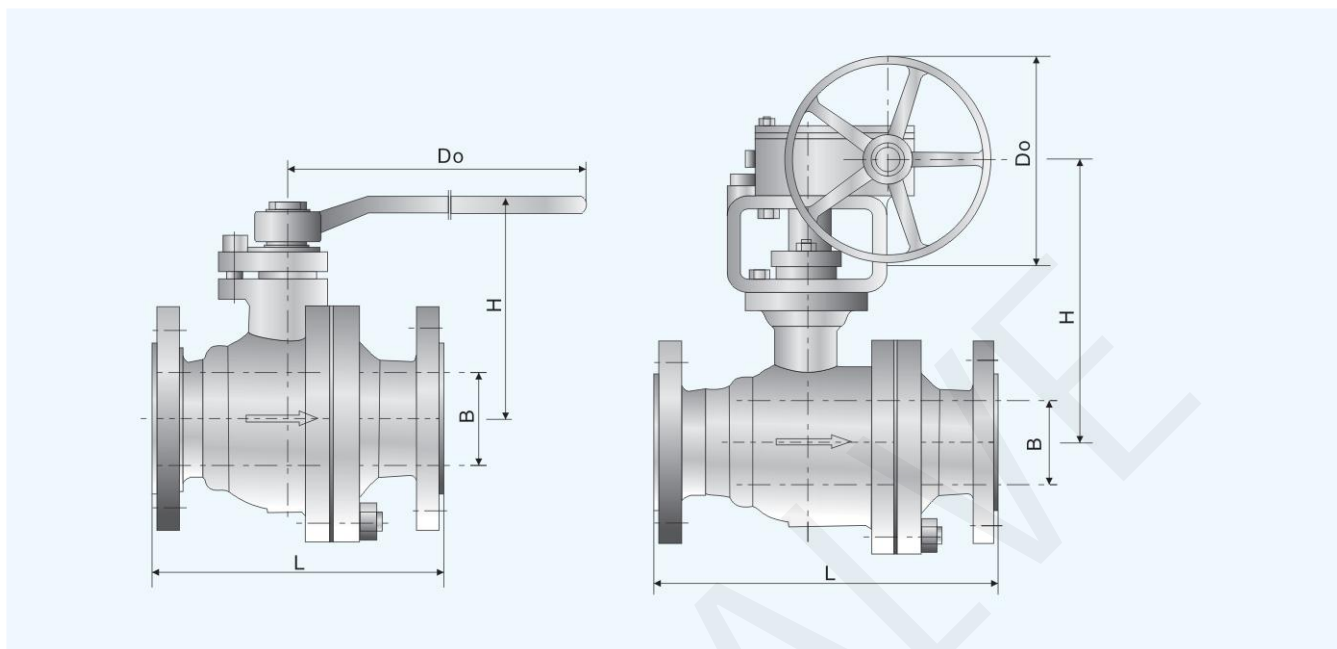

■ **Dimensions (Class 150/10K)**

| | | | | | | | | | | |
|----------|------|-----|------|-------|-----|-------|------|------|-----|-----|
| Size(in) | 1/2 | 3/4 | 1 | 1-1/2 | 2 | 1-1/2 | 3 | 4 | 6 | 8 |
| B(mm) | 12.7 | 19 | 25.4 | 38 | 51 | 64 | 76 | 102 | 152 | 203 |
| L(mm) | 108 | 117 | 127 | 165 | 178 | 190 | 203 | 229 | 267 | 292 |
| H(mm) | 54 | 59 | 64 | 90 | 102 | 112 | 121 | 166 | 208 | 246 |
| Do(mm) | 140 | 140 | 160 | 160 | 260 | 260 | 260 | 320 | 400 | 300 |
| WT(kg) | 2.1 | 3 | 4.1 | 6.5 | 9 | 11.2 | 15.3 | 28.6 | 53 | 81 |

■ **Dimensions (Class 300/20K)**

| | | | | | | | | | | |
|----------|------|-----|------|-------|-----|-------|-----|------|-----|-----|
| Size(in) | 1/2 | 3/4 | 1 | 1-1/2 | 2 | 1-1/2 | 3 | 4 | 6 | 8 |
| B(mm) | 12.7 | 19 | 25.4 | 38 | 51 | 64 | 76 | 102 | 152 | 203 |
| L(mm) | 140 | 152 | 165 | 190 | 216 | 241 | 282 | 305 | 403 | 419 |
| H(mm) | 54 | 59 | 64 | 90 | 102 | 112 | 121 | 166 | 208 | 246 |
| Do(mm) | 140 | 140 | 160 | 160 | 260 | 260 | 260 | 320 | 300 | 300 |
| WT(kg) | 2.8 | 3.6 | 4.9 | 10.4 | 10 | 16.1 | 23 | 39.5 | 82 | 124 |

■ **Dimensions (Class 600)**

| | | | | |
|----------|-----|------|------|-------|
| Size(in) | 1/2 | 3/4 | 1 | 1-1/2 |
| B(mm) | 13 | 19 | 25 | 38 |
| L(mm) | 165 | 190 | 216 | 241 |
| H(mm) | 180 | 180 | 250 | 300 |
| Do(mm) | 65 | 70 | 85 | 105 |
| WT(kg) | 8.5 | 11.5 | 16.3 | 19.5 |

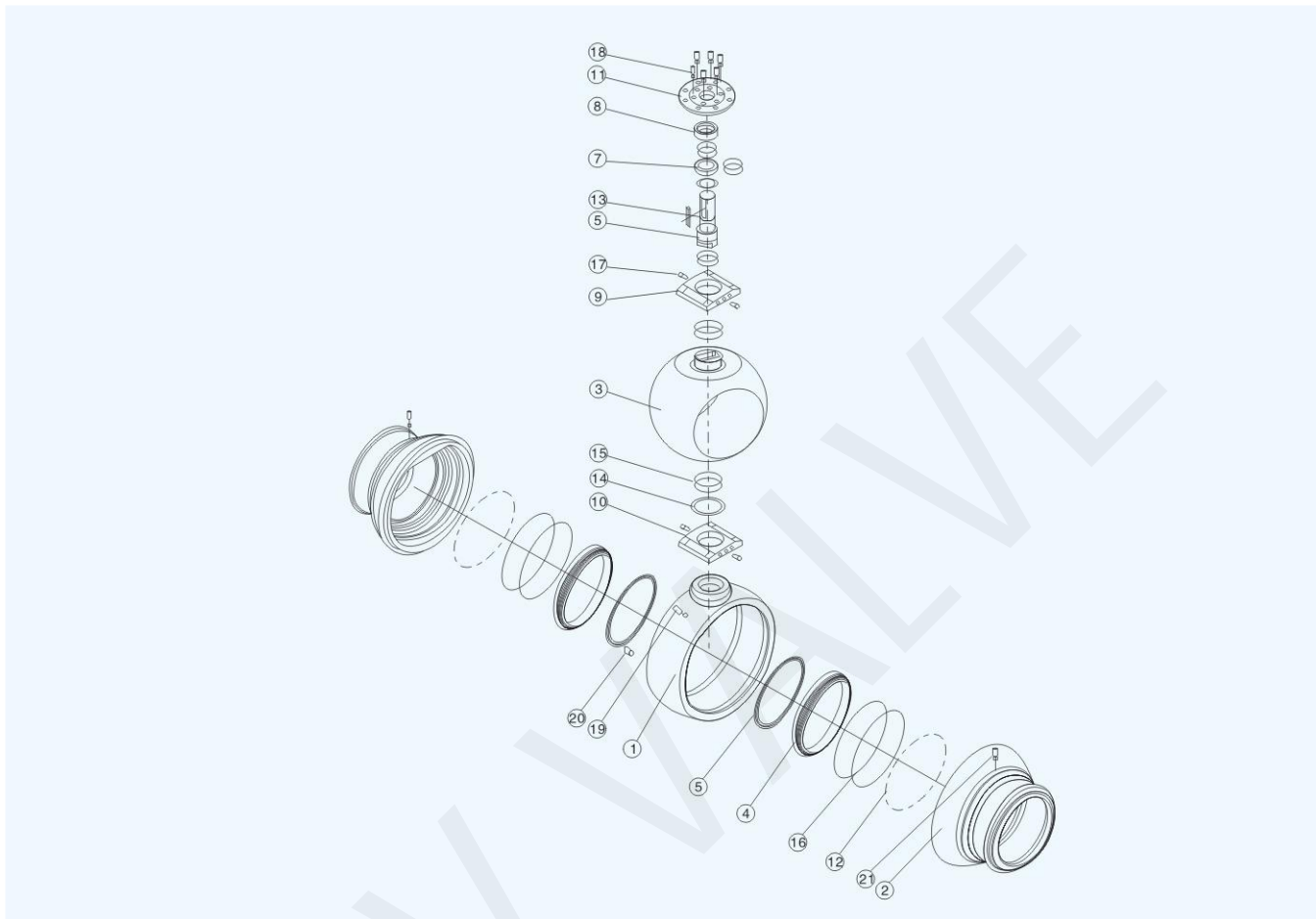

Material List

| No | Name | Materials | | |
|----|-------------------------|-------------------------|----------------------------|----------------------------|
| 1 | Body | ASTM A105 | ASTM A350 LF2 | ASTM A182 F316 |
| 2 | Bonnet | ASTM A105 | ASTM A350 LF2 | ASTM A182 F316 |
| 3 | Ball | ASTM A105+ENP | ASTM A350 LF2+ENP | ASTM A182 F316 |
| 4 | Seat | ASTM A105+ENP | ASTM A350 LF2+ENP | ASTM A182 F316 |
| 5 | Seal Ring | PTFE/MOLON/PEEK | PTFE/MOLON/PEEK | PTFE/MOLON/PEEK |
| 6 | Stem | ASTM A182 F6a | ASTM A350 LF2 | ASTM A182 F316 |
| 7 | Stuffing Box | ASTM A 182 F6a | ASTM A 276 410 | ASTM A 182 F316 |
| 8 | Packing Gland | ASTM A105 | ASTM A350 LF2 | ASTM A 182 F316 |
| 9 | Up Support Plate | ASTM A105 | ASTM A350 LF2 | ASTM A 182 F316 |
| 10 | Down Support Plate | ASTM A105 | ASTM A350 LF2 | ASTM A 182 F316 |
| 11 | Adapter | ASTM A105 | ASTM A350 LF2 | ASTM A 182 F316 |
| 12 | Spring | Inconel x-750 | Inconel x-750 | Inconel x-750 |
| 13 | Key | 45 | 45 | 45 |
| 14 | Gasket | Stainless Steel+PTFE | Stainless Steel+PTFE | Stainless Steel+PTFE |
| 15 | Bushing | Carbon steel+PTFE | Carbon steel+PTFE | Carbon steel+PTFE |
| 16 | "O"ring | Fluorone Rubber | Fluorone Rubber | Fluorone Rubber |
| 17 | Pin | 35 | ASTM A276 410 | ASTM A182 F316 |
| 18 | Nut | ASTM A 193 B7M | ASTM A 320 L7M | ASTM A 193 B8 |
| 19 | Relief Valve | Carbon steel components | Stainless steel components | Stainless steel components |
| 20 | Drain Valve | Carbon steel components | Stainless steel components | Stainless steel components |
| 21 | Fitting injection Valve | Carbon steel components | Stainless steel components | Stainless steel components |

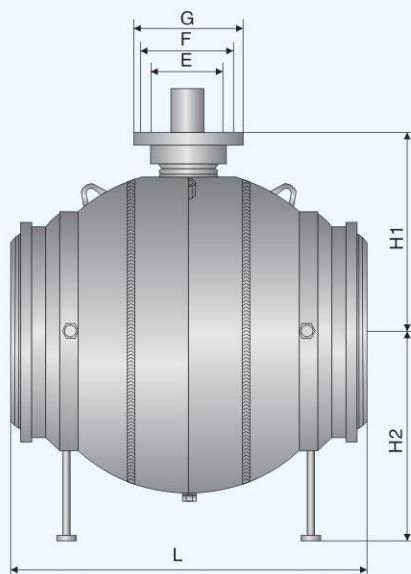

Valve CHART 1 (Bare Shaft)

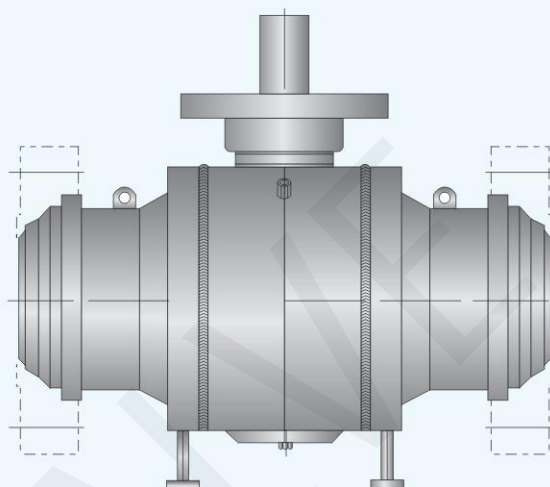

Valve CHART 2 (Bare Shaft)

| SIZE | DN | L(BW) | L(RF) | L(RTJ) | E | F | G | n-d1 | H1 | H2 | WT(kg) |
|------|------|-------|-------|--------|-----|-----|-----|--------|------|------|--------|
| 6 | 150 | 457 | 394 | 407 | 100 | 140 | 175 | 4-M16 | 235 | 200 | 180 |
| 8 | 200 | 521 | 457 | 470 | 130 | 165 | 210 | 4-M20 | 286 | 280 | 250 |
| 10 | 250 | 559 | 533 | 546 | 130 | 165 | 210 | 4-M20 | 325 | 320 | 400 |
| 12 | 300 | 635 | 610 | 622 | 130 | 165 | 210 | 4-M20 | 368 | 355 | 560 |
| 14 | 350 | 762 | 686 | 699 | 200 | 254 | 210 | 8-M16 | 405 | 400 | 830 |
| 16 | 400 | 838 | 762 | 775 | 200 | 254 | 300 | 8-M16 | 446 | 470 | 1050 |
| 18 | 450 | 914 | 864 | 877 | 200 | 254 | 300 | 8-M16 | 493 | 510 | 1450 |
| 20 | 500 | 991 | 914 | 927 | 230 | 298 | 350 | 8-M20 | 542 | 550 | 1750 |
| 22 | 550 | 1092 | -- | -- | 230 | 298 | 350 | 8-M20 | 580 | 600 | 2230 |
| 24 | 600 | 1143 | 1067 | 1080 | 230 | 298 | 350 | 8-M20 | 618 | 660 | 2850 |
| 26 | 650 | 1245 | 1143 | -- | 230 | 298 | 350 | 8-M20 | 669 | 700 | 2980 |
| 28 | 700 | 1345 | 1245 | -- | 230 | 356 | 415 | 8-M30 | 710 | 760 | 3500 |
| 30 | 750 | 1397 | 1295 | -- | 260 | 356 | 415 | 8-M30 | 750 | 780 | 4800 |
| 32 | 800 | 1524 | 1372 | -- | 260 | 356 | 415 | 8-M30 | 810 | 845 | 5500 |
| 34 | 850 | 1626 | 1473 | -- | -- | -- | -- | -- | -- | -- | -- |
| 36 | 900 | 1727 | 1524 | -- | 300 | 406 | 475 | 8-M36 | 890 | 1000 | 8500 |
| 38 | 950 | -- | -- | -- | -- | -- | -- | -- | -- | -- | -- |
| 40 | 1000 | 1956 | 1753 | -- | 300 | 406 | 475 | 8-M36 | 960 | 1200 | 11500 |
| 42 | 1050 | 2083 | 1790 | -- | 300 | 406 | 475 | 8-M36 | 995 | 1280 | -- |
| 48 | 1200 | 1995 | 2388 | -- | 370 | 483 | 560 | 12-M36 | 1150 | 1350 | -- |
| 56 | 1400 | 2489 | 2489 | -- | 370 | 483 | 560 | 12-M36 | 1253 | 1430 | -- |
| 60 | 1500 | 2667 | 2667 | -- | 470 | 603 | 686 | 20-M36 | 1380 | 1550 | -- |

Class 300 Full port, split body, full weld ball valve



CLASS 300

| Size | DN | L(BW) | L(RF) | L(RTJ) | E | F | G | n-d1 | H1 | H2 | WT(kg) |
|------|------|-------|-------|--------|-----|-----|-----|--------|------|------|--------|
| 6 | 150 | 403 | 403 | 419 | 100 | 140 | 175 | 4-M16 | 235 | 200 | 200 |
| 8 | 200 | 521 | 502 | 518 | 130 | 165 | 210 | 4-M20 | 291 | 280 | 280 |
| 10 | 250 | 559 | 568 | 584 | 130 | 165 | 210 | 4-M20 | 328 | 320 | 410 |
| 12 | 300 | 635 | 648 | 664 | 200 | 254 | 300 | 8-M16 | 368 | 355 | 630 |
| 14 | 350 | 762 | 762 | 778 | 200 | 254 | 300 | 8-M16 | 410 | 400 | 900 |
| 16 | 400 | 838 | 838 | 854 | 200 | 254 | 300 | 8-M16 | 446 | 470 | 1155 |
| 18 | 450 | 914 | 914 | 930 | 230 | 298 | 350 | 8-M20 | 493 | 510 | 1580 |
| 20 | 500 | 991 | 991 | 1010 | 230 | 298 | 350 | 8-M20 | 542 | 555 | 1950 |
| 22 | 550 | 1092 | 1092 | 1114 | 230 | 298 | 350 | 8-M20 | 590 | 600 | 2530 |
| 24 | 600 | 1143 | 1143 | 1165 | 230 | 298 | 350 | 8-M20 | 641 | 660 | 2850 |
| 26 | 650 | 1245 | 1245 | 1270 | 260 | 356 | 415 | 8-M30 | 678 | 700 | 3360 |
| 28 | 700 | 1346 | 1346 | 1372 | 260 | 356 | 415 | 8-M30 | 720 | 760 | 3750 |
| 30 | 750 | 1397 | 1397 | 1422 | 260 | 356 | 415 | 8-M30 | 775 | 800 | 5500 |
| 32 | 800 | 1524 | 1524 | 1552 | 300 | 406 | 475 | 8-M36 | 815 | 850 | 5900 |
| 34 | 850 | 1626 | 1626 | 1654 | -- | -- | -- | -- | -- | -- | -- |
| 36 | 900 | 1727 | 1727 | 1755 | 300 | 406 | 475 | 8-M36 | 895 | 1000 | 9000 |
| 38 | 950 | -- | -- | -- | -- | -- | -- | -- | -- | -- | -- |
| 40 | 1000 | 1956 | 1956 | -- | 300 | 406 | 475 | 8-M36 | 970 | 1200 | 12000 |
| 42 | 1050 | 2083 | 2083 | -- | 300 | 406 | 475 | 8-M36 | 1050 | 1300 | -- |
| 48 | 1200 | 2170 | 2170 | -- | 370 | 483 | 560 | 12-M36 | 1200 | 1450 | -- |
| 56 | 1400 | 2743 | 2743 | -- | 470 | 603 | 686 | 20-M36 | 1330 | 1600 | -- |
| 60 | 1500 | 2820 | 2820 | -- | 470 | 603 | 686 | 20-M36 | 1480 | 1700 | -- |

■ **CLASS 600**

| SIZE | DN | L(BW) | L(RF) | L(RTJ) | E | F | G | n-d1 | H1 | H2 | T(kg) |
|------|------|-------|-------|--------|-----|-----|-----|--------|------|------|-------|
| 6 | 150 | 559 | 559 | 562 | 130 | 165 | 210 | 4-M20 | 247 | 210 | 250 |
| 8 | 200 | 660 | 660 | 663 | 200 | 254 | 300 | 8-M16 | 293 | 280 | 340 |
| 10 | 250 | 787 | 787 | 790 | 200 | 254 | 300 | 8-M16 | 334 | 320 | 580 |
| 12 | 300 | 838 | 838 | 841 | 200 | 254 | 300 | 8-M16 | 382 | 365 | 850 |
| 14 | 350 | 889 | 889 | 892 | 200 | 254 | 300 | 8-M16 | 416 | 400 | 1150 |
| 16 | 400 | 991 | 991 | 994 | 200 | 254 | 300 | 8-M16 | 469 | 475 | 1360 |
| 18 | 450 | 1092 | 1092 | 1095 | 230 | 298 | 350 | 8-M20 | 508 | 530 | 2120 |
| 20 | 500 | 1194 | 1194 | 1200 | 260 | 356 | 415 | 8-M30 | 571 | 585 | 2650 |
| 22 | 550 | 1295 | 1295 | 1305 | 260 | 356 | 415 | 8-M30 | 620 | 600 | 3200 |
| 24 | 600 | 1397 | 1397 | 1407 | 260 | 356 | 415 | 8-M30 | 651 | 660 | 3750 |
| 26 | 650 | 1448 | 1448 | 1461 | 260 | 356 | 415 | 8-M30 | 704 | 720 | 3900 |
| 28 | 700 | 1549 | 1549 | 1562 | 300 | 406 | 475 | 8-M36 | 760 | 760 | 4200 |
| 30 | 750 | 1651 | 1651 | 1664 | 300 | 406 | 475 | 8-M36 | 790 | 820 | 6000 |
| 32 | 800 | 1778 | 1778 | 1794 | 300 | 406 | 475 | 8-M36 | 835 | 860 | 6800 |
| 34 | 850 | 1930 | 1930 | 1946 | -- | -- | -- | -- | -- | -- | -- |
| 36 | 900 | 2083 | 2083 | 2099 | 370 | 483 | 560 | 12-M36 | 970 | 1020 | 10000 |
| 38 | 950 | -- | -- | -- | -- | -- | -- | -- | -- | -- | -- |
| 40 | 1000 | 1956 | 1956 | -- | 370 | 483 | 560 | 12-M36 | 1150 | 1230 | 14000 |
| 42 | 1050 | 2083 | 2083 | -- | 370 | 483 | 560 | 12-M36 | 1260 | 1320 | -- |
| 48 | 1200 | 2170 | 2170 | -- | 370 | 483 | 560 | 12-M36 | 1430 | 1470 | -- |
| 56 | 1400 | 2743 | 2743 | -- | 470 | 603 | 686 | 20-M36 | 1620 | 1640 | -- |
| 60 | 1500 | 2820 | 2820 | -- | 470 | 603 | 686 | 20-M36 | 1800 | 1830 | -- |

■ CLASS 900

| SIZE | DN | L(BW) | L(RF) | L(RTJ) | H1 | H2 | WT(kg) |
|------|------|-------|-------|--------|------|------|--------|
| 6 | 150 | 610 | 610 | 613 | 350 | 270 | 350 |
| 8 | 200 | 737 | 737 | 740 | 420 | 360 | 550 |
| 10 | 250 | 838 | 838 | 841 | 490 | 380 | 1000 |
| 12 | 300 | 965 | 965 | 968 | 620 | 420 | 1450 |
| 14 | 350 | 1029 | 1029 | 1039 | 665 | 460 | 1700 |
| 16 | 400 | 1130 | 1130 | 1140 | 725 | 510 | 1950 |
| 18 | 450 | 1219 | 1219 | 1232 | 810 | 570 | 2600 |
| 20 | 500 | 1321 | 1321 | 1334 | 850 | 630 | 3900 |
| 22 | 550 | -- | -- | -- | 880 | 720 | 5100 |
| 24 | 600 | 1549 | 1549 | 1568 | 920 | 800 | 6500 |
| 26 | 650 | -- | -- | -- | 960 | 885 | 8000 |
| 28 | 700 | 1753 | 1753 | 1775 | 1050 | 960 | 9500 |
| 30 | 750 | 1880 | 1880 | 1902 | 1100 | 1030 | 12000 |
| 32 | 800 | 2032 | 2032 | 2054 | 1180 | 1120 | 13200 |
| 34 | 850 | 2159 | 2159 | 2188 | 1200 | 1250 | 15600 |
| 36 | 900 | 2286 | 2286 | 2315 | 1250 | 1300 | 17000 |
| 40 | 1000 | 2410 | 2410 | 2438 | 1500 | 1560 | -- |
| 42 | 1050 | 2515 | 2515 | 2540 | 1630 | 1700 | -- |
| 48 | 1200 | 2620 | 2620 | 2850 | 1850 | 1860 | -- |

■ CLASS 1500

| SIZE | DN | L(BW) | L(RF) | L(RTJ) | H1 | H2 | WT(kg) |
|------|-----|-------|-------|--------|-----|-----|--------|
| 6 | 150 | 705 | 705 | 711 | 380 | 280 | 450 |
| 8 | 200 | 832 | 832 | 842 | 475 | 380 | 760 |
| 10 | 250 | 991 | 991 | 1001 | 510 | 490 | 1450 |
| 12 | 300 | 1130 | 1130 | 1146 | 595 | 600 | 2230 |
| 14 | 350 | 1257 | 1257 | 1276 | 645 | 710 | 2800 |
| 16 | 400 | 1384 | 1384 | 1406 | 685 | 830 | 4120 |

■ CLASS 2500

| SIZE | DN | L(BW) | L(RF) | L(RTJ) | H1 | H2 | WT(kg) |
|------|-----|-------|-------|--------|-----|-----|--------|
| 6 | 150 | 914 | 914 | 927 | 385 | 300 | 770 |
| 8 | 200 | 1022 | 1022 | 1038 | 495 | 400 | 1357 |
| 10 | 250 | 1270 | 1270 | 1292 | 530 | 510 | 2100 |
| 12 | 300 | 1422 | 1422 | 1444 | 615 | 620 | 3210 |
| 14 | 350 | 1681 | 1681 | 1681 | 665 | 730 | 5520 |
| 16 | 400 | 1918 | 1918 | 1918 | 700 | 850 | 6520 |

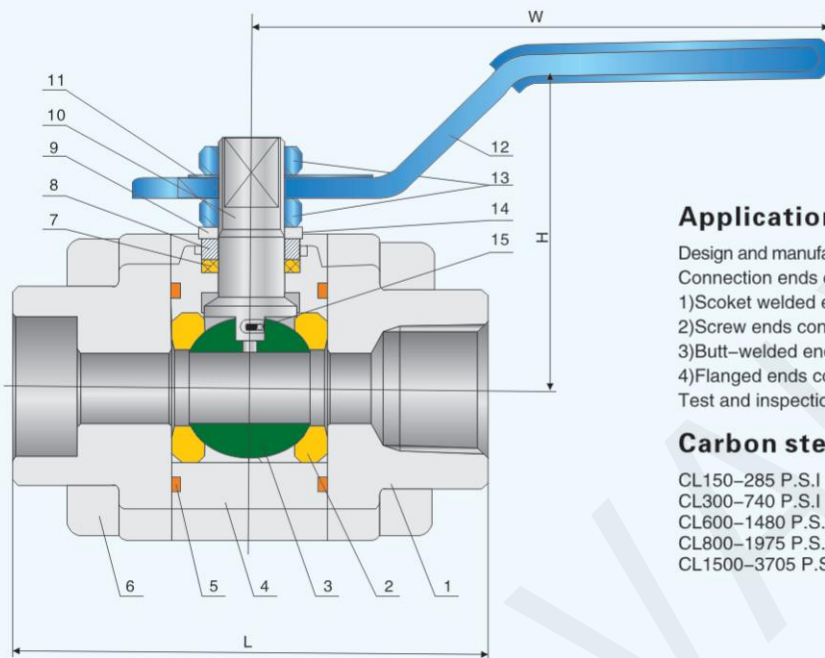

Application standards

Design and manufacture conform to BS 5351, MSS SP 118, JIS B2071, B2081;

Connection ends conform to :

1)Socket welded ends conform to ANSI B 16.11

2)Screw ends conform to ANSI B1.20.1

3)Butt-welded ends conform to ANSI B-16.25

4)Flanged ends conform to ANSI B 16.5

Test and inspection conform to:API 598, GB/T 13927, JB /T9092, JIS B2003

Carbon steel temperature-pressure rate

CL150-285 P.S.I @ 100° F

CL300-740 P.S.I @ 100° F

CL600-1480 P.S.I @ 100° F

CL800-1975 P.S.I @ 100° F

CL1500-3705 P.S.I @ 100° F

Material List

| No | Parts | Material | | | | |
|----|--------------------|--------------|--------------|--------------|--------------|--------------|
| 1 | Bonnet | A 105 | Lf2 | Lf2 | F316 | F316 |
| 2 | Seat | RPTFE & PEEK | RPTFE & PEEK | RPTFE & PEEK | RPTFE & PEEK | RPTFE & PEEK |
| 3 | Ball | F6 | F304 | F304(L) | F316(L) | F51 |
| 4 | Body | A105 | LF2 | F304(L) | F316(L) | F51 |
| 5 | O-ring | VITON | VITON | VITON | VITON | VITON |
| 6 | Stud | PTFE | B8 | B8 | B8M | B8M |
| 7 | Gasket | PTFE | PTFE | PTFE | PTFE | PTFE |
| 8 | Packing Bushing | 410 | PTFE | PTFE | PTFE | PTFE |
| 9 | Gland | 410 | 304 | F304(L) | F316(L) | F51 |
| 10 | Stem | F6 | 304 | F304(L) | F316(L) | F51 |
| 11 | Nameplate | Al | Al | Al | Al | Al |
| 12 | Lever | 1020+PVC | 1020+PVC | 1020+PVC | 1020+PVC | 1020+PVC |
| 13 | Nut | 2H | 8M | 8M | 8M | 8M |
| 14 | Elastic Washer | 65Mn | 65Mn | 304 | 304 | 304 |
| 15 | Anti-static Spring | 304 | 304 | 304 | 316L | 316L |

Class 800 / 1500 3PC Forged steel compact body ball valve

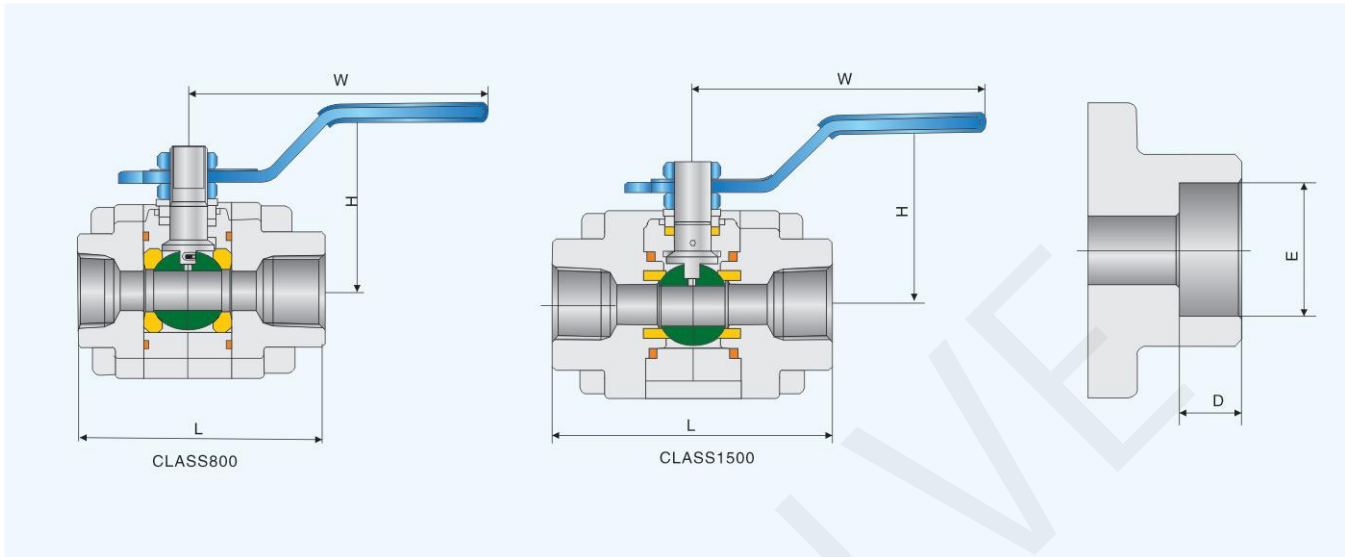

Full Bore Class 800/1500

| inch | | 1/4 | 3/8 | 1/2 | 3/4 | 1 | 1 1/4 | 1 1/2 | 2 |
|---------------------|------------|------|------|------|------|-----|-------|-------|-----|
| End to End(L=mm) | CLASS 800 | 67 | 67 | 73 | 88 | 105 | 116 | 128 | 146 |
| | CLASS 1500 | 73 | 73 | 88 | 105 | 116 | 128 | 146 | -- |
| Lever(W=mm) | CLASS 800 | 120 | 120 | 120 | 145 | 145 | 175 | 175 | 260 |
| | CLASS 1500 | 120 | 120 | 145 | 145 | 175 | 175 | 260 | -- |
| Center of Top(H=mm) | CLASS 800 | 50 | 50 | 52 | 60 | 65 | 86 | 93 | 110 |
| | CLASS 1500 | 52 | 52 | 60 | 60 | 86 | 93 | 110 | -- |
| Inside Bore(D=mm) | CLASS 800 | 11 | 11 | 14 | 20.5 | 25 | 31.6 | 38 | 49 |
| | CLASS 1500 | 11 | 11 | 14 | 20.5 | 25 | 31.6 | 38 | -- |
| WT(kg) | CLASS 800 | 0.75 | 0.75 | 0.95 | 1.7 | 2.4 | 3.7 | 4.9 | 8.7 |
| | CLASS 1500 | -- | 1.2 | 2.2 | 3.4 | 4.7 | 6.7 | 10.5 | -- |

Reduced Bore Class 800/1500

| inch | | 1/2 | 3/4 | 1 | 1 1/4 | 1 1/2 | 2 |
|---------------------|------------|------|------|------|-------|-------|------|
| End to End(L=mm) | CLASS 800 | 67 | 73 | 88 | 105 | 116 | 128 |
| | CLASS 1500 | 73 | 88 | 105 | 116 | 128 | 146 |
| Lever(W=mm) | CLASS 800 | 120 | 120 | 145 | 145 | 175 | 175 |
| | CLASS 1500 | 120 | 145 | 145 | 175 | 175 | 260 |
| Center of Top(H=mm) | CLASS 800 | 50 | 52 | 60 | 65 | 86 | 93 |
| | CLASS 1500 | 52 | 60 | 60 | 86 | 93 | 110 |
| Inside Bore(D=mm) | CLASS 800 | 11 | 14 | 20.5 | 25 | 31.6 | 38 |
| | CLASS 1500 | 11 | 14 | 20.5 | 25 | 31.6 | 38 |
| Weight(kg) | CLASS 800 | 0.75 | 0.95 | 1.7 | 2.4 | 3.7 | 4.9 |
| | CLASS 1500 | 1.2 | 2.2 | 3.4 | 4.7 | 6.7 | 10.5 |

| SOCKET WELD DIMENSIONS | | 1/4 | 3/8 | 1/2 | 3/4 | 1 | 1 1/4 | 1 1/2 | 2 |
|------------------------|-------|------|------|------|------|------|-------|-------|------|
| ANSI B 16.11 | E(mm) | 14.1 | 17.6 | 21.9 | 27.4 | 34.2 | 42.7 | 48.8 | 61.1 |
| | D(mm) | 9.6 | 9.6 | 9.6 | 12.7 | 12.7 | 12.7 | 12.7 | 15.9 |

■ Structural Characteristic

We use the Germany advanced technology and apply it in our new products by years of R&D, we develop Feiqiu special Top-entry ball valve. With technology up to domestic leading level, these products can compete with the international counterparts. Besides the features borne by the side installed fixed ball valve (see fixed ball valve), they are also given the features below:

1. One-piece valve body, top installed trunnion to fix and support, flanged or butt welded structure.
2. Inconel bellows spring makes the sealed metal seat moving toward the ball, providing the two way seal function of inlet and outlet.
3. Distinctive technology of retractable valve seat, inline replace ability of ball arm, valve stem sealing ring, metal seat and bellows spring, and torque down to the minimum for the ease of operation.
4. Ease of repair and installation, long performance life. Access for repair and replacement of trims may be done with no need to remove the valve from the pipeline, thus to lengthen the service life.
5. Low torque, reliable sealing, and spherical seat different from ordinary ball valves, which can automatically adjust the position of seal.
6. Preset platform and bolt holes for drive device, and to ISO5211. Drive device can be installed according to users' different requirements.
7. DBB (double block and bleed) function.
8. Hand operated top installed ball valve adopts high strength one-piece ball arm structure to ensure the precise positioning of the ball.
9. Anti-blowout protective structure of valve stem to enhance the operational safety of the valve.

■ Technical Specifications

| Technical Specifications | API series |
|------------------------------|------------------------|
| Design Specifications | API6D、API608、BS5351 |
| Pressure-Temperature Ratings | ASME B16.34 |
| Face-to-Face | API6D、ASME B16.10 |
| Flanged Ends | ASME B16.5、ASME B16.47 |
| Butt-welding Ends | ASME B16.25 |
| Inspection and Test | API6D、API598 |
| Fire-safe Test | API607、API 6FA |
| Castings Quality Inspection | MSS-SP-55 |

■ Torque Chart (N.M)

The torque ratings listed below are for the reference to choose a drive device. The properties of medium, trims and valve open frequency shall be considered as extra factors. For instance, valves with corrosion-resistant trims to deal with clean lubricating mediums, their torque may be lowered by 20%. However, to deal with stringent mediums like slurry, granular medium and oxygen, the torque may be increased by 50%. The operating torque of drawing-down valves is subject to the corresponding diameter to their neckings. (Specific options as per the actual).

| Size | | Pressure Class | | | | | | |
|-----------|-------|----------------|-----|------|------|------|------|-------|
| DN | NPS | 150 | 300 | 400 | 600 | 900 | 1500 | 2500 |
| 50 × 40 | 1 1/2 | 61 | 81 | 85 | 102 | 149 | – | – |
| 50 | 2 | 68 | 108 | 97 | 136 | 203 | 333 | 562 |
| 80 × 50 | 3 × 2 | 68 | 108 | 97 | 136 | 203 | 333 | 562 |
| 80 | 3 | 149 | 244 | 204 | 305 | 422 | 811 | 1460 |
| 100 × 80 | 4 × 3 | 149 | 244 | 204 | 305 | 422 | 811 | 1460 |
| 100 | 4 | 244 | 407 | 422 | 453 | 583 | 1505 | 1923 |
| 150 × 100 | 6 × 4 | 244 | 407 | 422 | 453 | 583 | 1505 | 1923 |
| 150 | 6 | 323 | 544 | 647 | 1006 | 1299 | 2940 | 5840 |
| 200 × 150 | 8 × 6 | 323 | 544 | 647 | 1006 | 1299 | 2940 | 5840 |
| 200 | 8 | 647 | 955 | 1157 | 2532 | 2766 | 6489 | 12181 |

Trunnion mounted top entry ball valve



| Size | | Pressure Class | | | | | | |
|-----------|---------|----------------|-------|-------|--------|-------|-------|-------|
| DN | NPS | 150 | 300 | 400 | 600 | 900 | 1500 | 2500 |
| 250 × 200 | 10 × 8 | 647 | 955 | 1157 | 2532 | 2766 | 6489 | 12181 |
| 250 | 10 | 882 | 1822 | 2178 | 3941 | 5446 | 12181 | 15281 |
| 300 × 250 | 12 × 10 | 882 | 1822 | 2178 | 3941 | 5446 | 12181 | 15281 |
| 350 × 250 | 14 × 10 | 882 | 1822 | 2178 | 3941 | 5446 | 12181 | 15281 |
| 300 | 12 | 1577 | 2591 | 3064 | 6893 | 7909 | 15564 | 19834 |
| 350 × 300 | 14 × 12 | 1577 | 2591 | 3064 | 6893 | 7909 | 15564 | - |
| 400 × 300 | 16 × 12 | 1577 | 2591 | 3064 | 6893 | 7909 | 15564 | - |
| 350 | 14 | 1873 | 3224 | 3853 | 6205 | 10948 | 23512 | - |
| 400 × 350 | 16 × 14 | 1873 | 3224 | 3853 | 6205 | 10948 | 23512 | - |
| 400 | 16 | 3050 | 5447 | 6529 | 8817 | 13682 | 27039 | - |
| 450 × 400 | 18 × 16 | 3050 | 5447 | 6529 | 8817 | 13682 | 27039 | - |
| 500 × 400 | 20 × 16 | 3050 | 5447 | 6529 | 8817 | 13682 | 27039 | - |
| 450 | 18 | 3819 | 6197 | 7461 | 11231 | 17705 | 37085 | - |
| 500 | 20 | 4508 | 7830 | 9348 | 14919 | 29866 | 40309 | - |
| 550 | 22 | 5490 | 9453 | 11302 | 16058 | 39324 | - | - |
| 600 × 500 | 24 × 20 | 4508 | 7830 | 9348 | 15140 | 29866 | 40309 | - |
| 600 | 24 | 6723 | 11457 | 15535 | 21840 | 40810 | 64671 | - |
| 650 | 26 | 9289 | 15139 | 17869 | 24889 | 51822 | - | - |
| 700 | 28 | 11647 | 18067 | 21063 | 28767 | 53515 | - | - |
| 750 × 600 | 30 × 24 | 6723 | 11457 | 15535 | 21840 | 40810 | - | - |
| 750 | 30 | 13558 | 19207 | 24966 | 34398 | 57057 | - | - |
| 800 | 32 | 15224 | 24095 | 28235 | 38880 | 61123 | - | - |
| 850 | 34 | 17846 | 30249 | 33291 | 41789 | 70277 | - | - |
| 900 × 750 | 36 × 30 | 13558 | 19207 | 24966 | 34398 | 57057 | - | - |
| 900 | 36 | 22032 | 33331 | 36227 | 51521 | 81349 | - | - |
| 1000 | 40 | 25972 | 36490 | 45269 | 60368 | - | - | - |
| 1050 | 42 | 27034 | 40425 | 53515 | 70277 | - | - | - |
| 1200 | 48 | 42606 | 64985 | 79311 | 112293 | - | - | - |

■ Products Supply Range

| Size | | Pressure Class | | | | | |
|-----------|-----------|----------------|-------|---------|-----|-------|-------|
| DN | NPS | 150 | 300 | 600 | 900 | 1500 | 2500 |
| 50 × 40 | 2 × 2 1/2 | | ●/△ | | | ☆/△ | |
| 50 | 2 | | ●/△ | | | ☆/△ | |
| 80 × 50 | 3 × 2 | | ●/△ | | | ☆/△ | |
| 80 | 3 | | ☆/△ | | | ☆/△ | |
| 100 × 80 | 4 × 3 | | ☆/△ | | | ☆/△ | |
| 100 | 4 | | ☆/△ | | | ☆/△ | |
| 150 × 100 | 6 × 4 | | ☆/△ | | | ☆/△ | |
| 150 | 6 | ●/☆/△/★ | | ☆/△/★ | | ☆/△/★ | |
| 200 × 150 | 8 × 6 | ☆/△/★ | | ●/☆/△/★ | | ☆/△/★ | |
| 200 | 8 | ☆/△/★ | | ●/☆/△/★ | | ☆/△/★ | ☆/△/★ |
| 250 × 200 | 10 × 8 | | ☆/△/★ | | | ☆/△/★ | ☆/△/★ |
| 250 | 10 | | ☆/△/★ | | | ☆/△/★ | ☆/△/★ |
| 300 × 250 | 12 × 10 | | ☆/△/★ | | | ☆/△/★ | ☆/△/★ |
| 350 × 250 | 14 × 10 | | ☆/△/★ | | | ☆/△/★ | ☆/△/★ |
| 300 | 12 | | ☆/△/★ | | | ☆/△/★ | ☆/△/★ |
| 350 × 300 | 14 × 12 | | ☆/△/★ | | | ☆/△/★ | – |
| 400 × 300 | 16 × 12 | | ☆/△/★ | | | ☆/△/★ | – |
| 350 | 14 | | ☆/△/★ | | | ☆/△/★ | – |
| 400 × 350 | 16 × 14 | | ☆/△/★ | | | ☆/△/★ | – |
| 400 | 16 | | ☆/△/★ | | | ☆/△/★ | – |
| 450 × 400 | 18 × 16 | | ☆/△/★ | | | ☆/△/★ | – |
| 500 × 400 | 20 × 16 | | ☆/△/★ | | | ☆/△/★ | – |
| 450 | 18 | | ☆/△/★ | | | ☆/△/★ | – |
| 500 | 20 | | ☆/△/★ | | | ☆/△/★ | – |
| 550 | 22 | | ☆/△/★ | | | ☆/△/★ | – |
| 600 × 500 | 24 × 20 | | ☆/△/★ | | | ☆/△/★ | – |
| 600 | 24 | | ☆/△/★ | | | ☆/△/★ | – |
| 650 | 26 | | ☆/△/★ | | | – | – |
| 700 | 28 | | ☆/△/★ | | | – | – |
| 750 × 600 | 30 × 24 | | ☆/△/★ | | | – | – |
| 750 | 30 | | ☆/△/★ | | | – | – |
| 800 | 32 | | ☆/△/★ | | | – | – |
| 850 | 34 | | ☆/★ | | | – | – |
| 900 × 750 | 36 × 30 | | ☆/△/★ | | | – | – |
| 900 | 36 | | ☆/★ | | | – | – |
| 1000 | 40 | | ☆/★ | | | – | – |
| 1050 | 42 | | ☆/★ | | | – | – |
| 1200 | 48 | | ☆/★ | | | – | – |

Note: ● Stands for handle operated valves
 △ Stands for gearbox operated valves
 ☆ Stands for air operated valves
 ★ Stands for electric operated valves
 – Stands for no option

It can be manufactured according to user's requirements if not covered in the table.

Trunnion mounted top entry ball valve



Performance Specification

| Performance Specification | | Pressure Class | | | | | | |
|---------------------------|---------------|--|------|-------|-------|-------|-------|-------|
| | | 150 | 300 | 400 | 600 | 900 | 1500 | 2500 |
| Test Pressure (MPa) | Strength Test | 2.94 | 7.67 | 10.20 | 15.30 | 22.98 | 38.30 | 63.83 |
| | Sealing Test | 2.16 | 5.62 | 7.48 | 11.23 | 16.85 | 28.08 | 46.81 |
| | Air Test | 0.6 | | | | | | |
| Applicable Temperature | | -196°C ~ 550 (Different materials for different working conditions) | | | | | | |
| Applicable Medium | | Water, Steam, Oil, Gas, Liquid Gas, Natural Gas etc | | | | | | |
| Size Range | | DN50 ~ 1200(NP2" ~ 48"), We can produce according to your special requirements. | | | | | | |
| Body/Trim Material | | Carbon Steel, Stainless Steel, Duplex Stainless Steel, Ni-Alloy Steel, Ti Material | | | | | | |
| Ends Connection | | Flange Connection, Butt-welded Connection | | | | | | |
| Actuating Device | | Lever, Gearbox, Electric, Pneumatic etc. | | | | | | |

Valve Structural Schematic Drawing (Manual Top Entry Ball Valve)

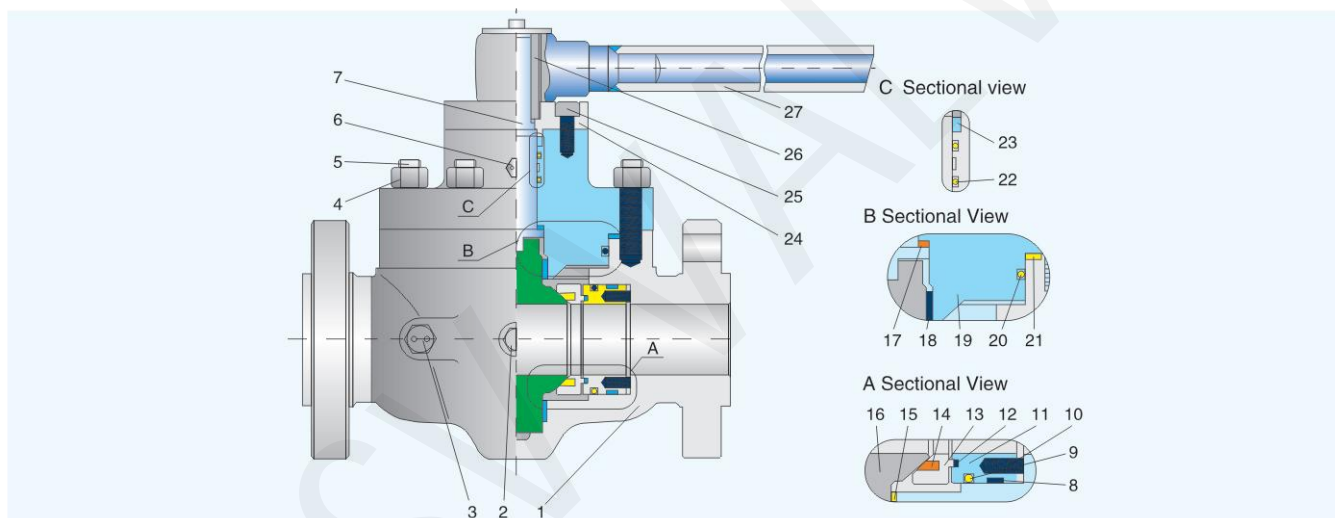

The Material of Main Parts

| No. | Parts Name | Material | | |
|-----|-------------------------|--|-----------|-----------------------|
| | | Carbon Steel | SS | Low Temperature Steel |
| 1 | Body | A216 WCB | A351 CF8M | A352 LCC |
| 2 | Drain Valve | A29 1025 | SS | SS |
| 3 | Sealant Injection Valve | A29 1025 | SS | SS |
| 4 | Nut | A194 2H | A194 8 | A194 7 |
| 5 | Stud | A193 B7 | A193 B8 | A320 L7 |
| 6 | Sealant Injection Valve | A29 1025 | SS | SS |
| 7 | Stem | A182 F6a | A182 F316 | A182 F316 |
| 8 | Fire Safe Ring | Soft Graphite | | |
| 9 | O-Ring | VITON | | |
| 10 | Spring | INCONEL X-750 | | |
| 11 | Supporting Ring | A29 4140+ENP | A182 F316 | A350 LF3 |
| 12 | Gasket | Soft Graphite+SS | | |
| 13 | Seat | A105+ENP A29 4140+ENP A182 F316 A350 LF3 | | |
| 14 | Sealing Ring | PTFE, NYLON, PEEK, PCTFE, MOLON | | |
| 15 | Bushing | PTFE+CS | PTFE+SS | PTFE+SS |
| 16 | Ball | A105+ENP | A182+E316 | A350+LF3 |
| 17 | Flat Bushing | PTFE+CS | PTFE+SS | PTFE+SS |
| 18 | Bushing | PTFE+CS | PTFE+SS | PTFE+SS |
| 19 | Bonnet | A216 WCB | A351 CF8M | A352 LCC |
| 20 | O-Ring | VITON | | |
| 21 | Gasket | Soft Graphite+SS | | |
| 22 | O-Ring | VITON | | |
| 23 | Packing | Soft Graphite | | |
| 24 | Cover | A29 4140+ENP | A182 F316 | A350 LF3 |
| 25 | Screw | A193 B7 | A193 B8 | A320 L7 |
| 26 | Key | A29 1045 | A29 1045 | A29 1045 |
| 27 | Lever | Q235A | | |

Notes: 1. Materials are available according to users' requirements and different working medium
 2. Materials for Anti-sulfur valve shall be chosen according to NACE MR0175.

Valve Structural Schematic Drawing (Top Entry Ball Valve)

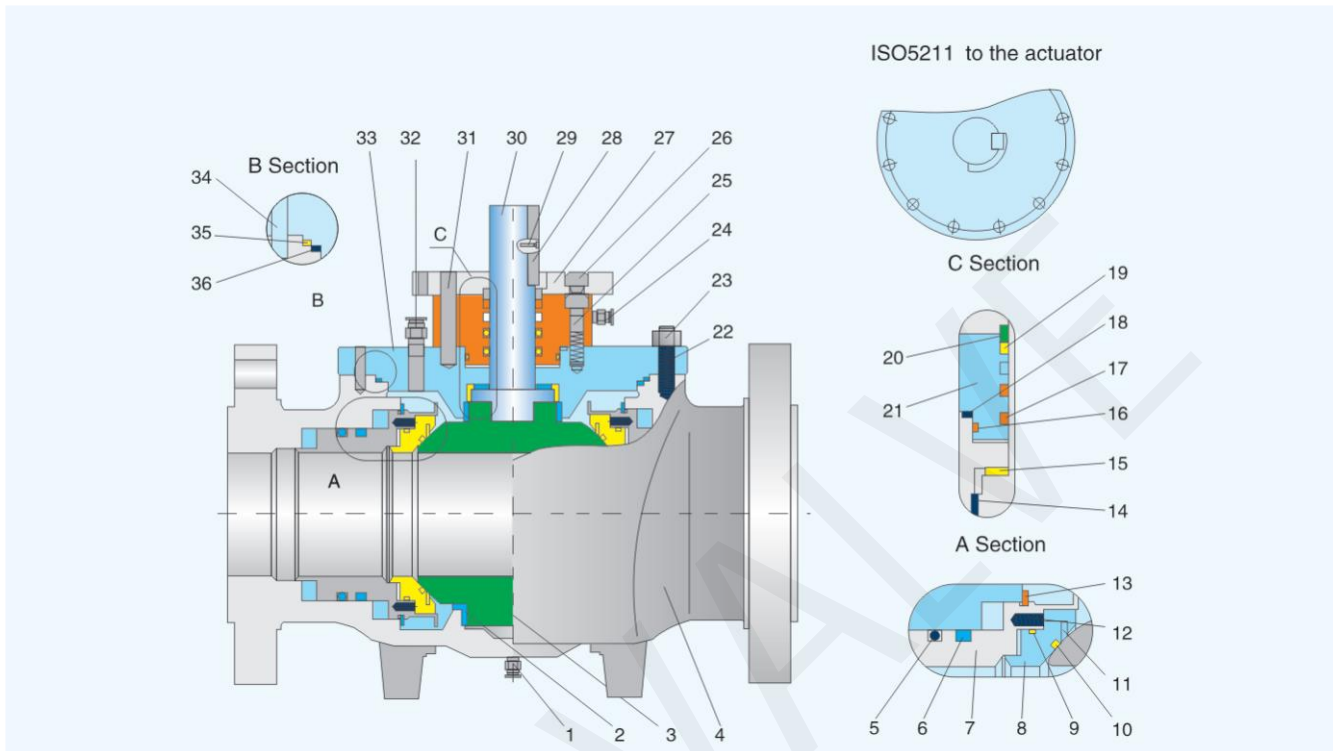

The Material of Main Parts

| No. | Parts Name | Material | | |
|-----|-------------------|---------------------------|-----------|-----------------------|
| | | Carbon Steel | SS | Low Temperature Steel |
| 1 | Drain Valve | A29 1025 | SS | SS |
| 2 | Bushing | PTFE+CS | PTFE+SS | PTFE+SS |
| 3 | Ball | A105+ENP | A182 F316 | A350 LF3 |
| 4 | Stem | A216 WCB | A351 CF8M | A352 LCC |
| 5 | O-Ring | VITON | | |
| 6 | Fire Safe Ring | Soft Graphite | | |
| 7 | Supporting Ring | A29 4140+ENP | A182 F316 | A350 LF3 |
| 8 | Seat | A105+ENP | A182 F316 | A350 LF3 |
| 9 | O-Ring | VITON | | |
| 10 | O-Ring | VITON | | |
| 11 | Sealing Ring | PTFE, NYLON, PCTFE, MOLON | | |
| 12 | Spring | INCONEL X-750 | | |
| 13 | C Type Spring | 17-4 | | |
| 14 | Bushing | PTFE+CS | PTFE+SS | PTFE+SS |
| 15 | Flat Bush Bearing | PTFE+CS | PTFE+SS | PTFE+SS |
| 16 | O-Ring | VITON | | |
| 17 | O-Ring | VITON | | |
| 18 | Gasket | Soft Graphite+SS | | |

| No. | Parts Name | Material | | |
|-----|-------------------------|------------------|-----------|-----------------------|
| | | Carbon Steel | SS | Low Temperature Steel |
| 19 | Packing | Soft Graphite | | |
| 20 | Gland | A182 F6a | A182 F6a | A350 LF3 |
| 21 | Cover | A29 4140+ENP | A182 F6a | A320 L7 |
| 22 | Stud | A193 B7 | A193 B8 | A194 7 |
| 23 | Nut | A194 2H | A194 8 | A350 LF3 |
| 24 | Sealant Injection Valve | A29 1025 | SS | SS |
| 25 | Screw | A193 B7 | A193 B8 | A320 L7 |
| 26 | Screw | A193 B7 | A193 B8 | |
| 27 | Connecting Plate | A105 | | |
| 28 | Key | A29 1045 | | |
| 29 | Screw | A193 B7 | | |
| 30 | Stem | A182 F6a | A182 F316 | A182 F316 |
| 31 | Locating Pin | A182 F6a | | |
| 32 | Sealant Injection Valve | A29 1025 | SS | SS |
| 33 | Bonnet | A216 WCB | A351 CF8M | A352 LCC |
| 34 | Locating Pin | A182 F6a | | |
| 35 | Gasket | Soft Graphite+SS | | |
| 36 | O-Ring | VITON | | |

Note: 1. Materials are chosen according to the temperature & pressure for different working mediums.

2. It can be available to choose the materials according to user's requirements, besides the listed material in the chart.

3. Materials in accordance with NACE MR-01-75 (latest edition) are available for sour gas service.

Remarks: RF stands for Raised Flange Connection; BW stands for Buttwelded Ends Connection; RTJ stands for Ring Joint Connection.

Class 150 Trunnion mounted top entry ball valve

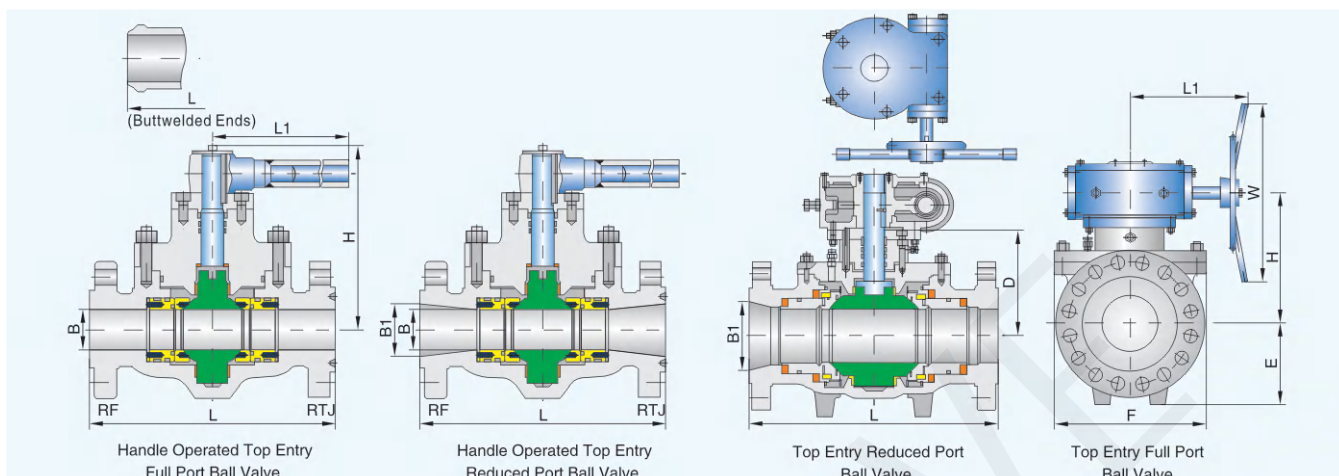

■ Main Outline Dimensions

Class 150 Full Port

mm

| DN (mm) | NPS (in) | L | | | B | B1 | D | E | F | H | L1 | W | Weight (kg) RF |
|------------|-------------|------|------|------|------|------|------|------|------|------|-----|------|-------------------|
| | | RF | BW | RTJ | | | | | | | | | |
| 50 | 2 | 178 | 191 | 216 | 51 | 51 | - | 85 | 180 | 212 | 450 | - | 28 |
| 80 | 3 | 203 | 216 | 283 | 77 | 77 | - | 112 | 230 | 228 | 600 | - | 55 |
| 100 | 4 | 229 | 241 | 305 | 102 | 102 | - | 145 | 283 | 272 | 600 | - | 105 |
| 150 | 6 | 394 | 406 | 457 | 152 | 152 | 281 | 220 | 325 | 333 | 297 | 350 | 235 |
| 200 | 8 | 457 | 470 | 521 | 203 | 203 | 320 | 260 | 405 | 384 | 360 | 500 | 430 |
| 250 | 10 | 533 | 546 | 559 | 254 | 254 | 360 | 311 | 490 | 424 | 360 | 500 | 475 |
| 300 | 12 | 610 | 622 | 635 | 305 | 305 | 403 | 366 | 570 | 467 | 340 | 700 | 610 |
| 350 | 14 | 686 | 699 | 762 | 337 | 337 | 453 | 428 | 660 | 517 | 340 | 700 | 795 |
| 400 | 16 | 762 | 775 | 838 | 387 | 387 | 459 | 450 | 700 | 549 | 545 | 700 | 1160 |
| 450 | 18 | 864 | 876 | 914 | 438 | 438 | 502 | 473 | 755 | 577 | 575 | 700 | 1570 |
| 500 | 20 | 914 | 927 | 991 | 489 | 489 | 551 | 580 | 870 | 626 | 575 | 700 | 2000 |
| 550 | 22 | 991 | 1062 | 1092 | 540 | 540 | 578 | 590 | 955 | 653 | 575 | 700 | 2830 |
| 600 | 24 | 1067 | 1080 | 1143 | 591 | 591 | 606 | 600 | 1030 | 696 | 579 | 700 | 3300 |
| 650 | 26 | 1143 | 1168 | 1245 | 635 | 635 | 675 | 635 | 1075 | 765 | 570 | 700 | 3970 |
| 700 | 28 | 1245 | 1270 | 1346 | 686 | 686 | 735 | 700 | 1165 | 825 | 579 | 700 | 4755 |
| 750 | 30 | 1295 | 1321 | 1397 | 736 | 736 | 795 | 775 | 1250 | 865 | 579 | 700 | 5820 |
| 800 | 32 | 1372 | 1400 | 1524 | 781 | 781 | 840 | 825 | 1325 | 1012 | 605 | 620 | 7240 |
| 850 | 34 | 1473 | 1502 | 1626 | 832 | 832 | 875 | 880 | 1410 | 1047 | 605 | 620 | 7960 |
| 900 | 36 | 1524 | 1552 | 1727 | 876 | 876 | 931 | 930 | 1475 | 1103 | 605 | 620 | 9300 |
| 1000 | 40 | 1753 | - | 1956 | 978 | 978 | 1015 | 1025 | 1640 | 1170 | 950 | 1400 | 12950 |
| 1050 | 42 | 1855 | - | 2083 | 1022 | 1022 | 1065 | 1080 | 1710 | 1220 | 950 | 1400 | 15200 |
| 1200 | 48 | 2134 | - | 2388 | 1168 | 1168 | 1180 | 1225 | 1940 | 1335 | 950 | 1400 | 22750 |

Class 150 Reduced Port

mm

| DN (mm) | NPS (in) | L | | | B | B1 | D | E | F | H | L1 | W | Weight (kg) RF |
|------------|-------------|------|------|------|-----|-----|-----|-----|------|-----|-----|-----|-------------------|
| | | RF | BW | RTJ | | | | | | | | | |
| 50 x 40 | 2 x 1 1/2 | 178 | 191 | 216 | 38 | 51 | - | 85 | 180 | 212 | 450 | - | 25 |
| 80 x 50 | 3 x 2 | 203 | 216 | 283 | 51 | 77 | - | 85 | 180 | 212 | 450 | - | 37 |
| 100 x 80 | 4 x 3 | 229 | 241 | 305 | 77 | 102 | - | 112 | 230 | 228 | 600 | - | 75 |
| 150 x 100 | 6 x 4 | 394 | 406 | 457 | 102 | 152 | - | 145 | 283 | 272 | 600 | - | 140 |
| 200 x 150 | 8 x 6 | 457 | 470 | 521 | 152 | 203 | 281 | 220 | 325 | 333 | 297 | 350 | 265 |
| 250 x 200 | 10 x 8 | 533 | 546 | 559 | 203 | 254 | 320 | 260 | 405 | 384 | 360 | 500 | 480 |
| 300 x 250 | 12 x 10 | 610 | 622 | 635 | 254 | 305 | 360 | 311 | 490 | 424 | 360 | 500 | 510 |
| 350 x 250 | 14 x 10 | 686 | 699 | 762 | 254 | 337 | 360 | 311 | 490 | 424 | 360 | 500 | 690 |
| 350 x 300 | 14 x 12 | 686 | 699 | 762 | 305 | 337 | 403 | 366 | 570 | 467 | 340 | 700 | 820 |
| 400 x 300 | 16 x 12 | 762 | 775 | 838 | 305 | 387 | 403 | 366 | 570 | 467 | 340 | 700 | 970 |
| 400 x 350 | 16 x 14 | 762 | 775 | 838 | 387 | 337 | 453 | 428 | 660 | 517 | 340 | 700 | 955 |
| 450 x 400 | 18 x 16 | 864 | 876 | 914 | 387 | 438 | 450 | 450 | 700 | 549 | 545 | 700 | 1295 |
| 500 x 400 | 20 x 16 | 914 | 927 | 991 | 387 | 489 | 459 | 450 | 700 | 549 | 545 | 700 | 1590 |
| 500 x 450 | 20 x 18 | 914 | 927 | 991 | 438 | 489 | 502 | 473 | 755 | 577 | 575 | 700 | 1800 |
| 600 x 500 | 24 x 20 | 1067 | 1080 | 1143 | 489 | 591 | 551 | 580 | 870 | 626 | 575 | 700 | 2440 |
| 750 x 600 | 30 x 24 | 1295 | 1321 | 1397 | 591 | 736 | 606 | 600 | 1030 | 696 | 579 | 700 | 4100 |
| 900 x 750 | 36 x 30 | 1524 | 1552 | 1727 | 736 | 876 | 795 | 775 | 1250 | 865 | 579 | 700 | 7200 |

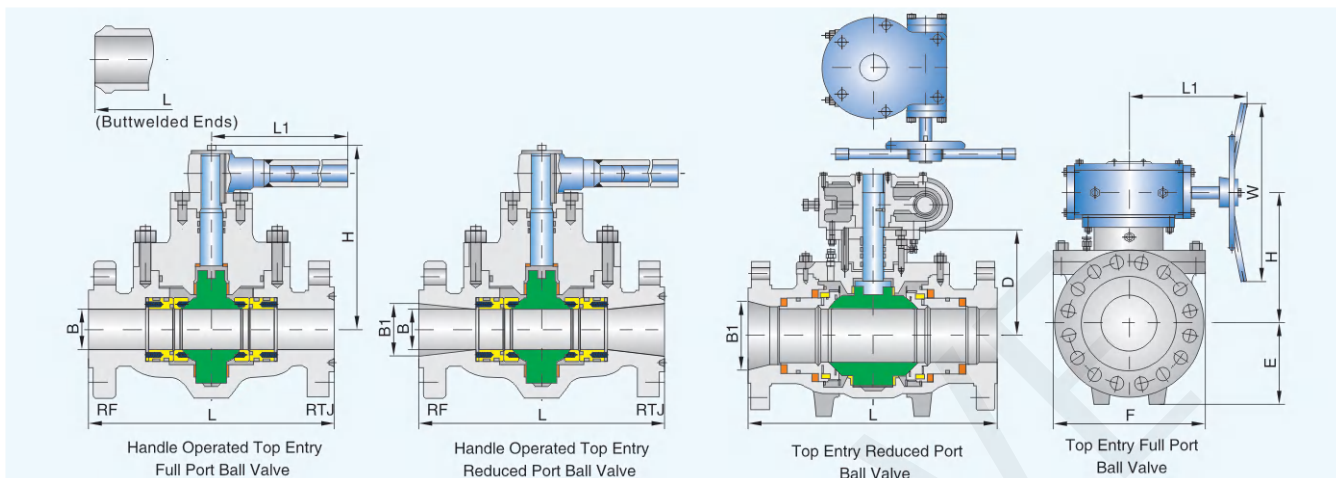

■ Main Outline Dimensions

Class 300 Full Port

mm

| DN (mm) | NPS (in) | L | | | B | B1 | D | E | F | H | L1 | W | Weight (kg) RF |
|------------|-------------|------|------|------|------|------|------|------|------|------|------|------|-------------------|
| | | RF | BW | RTJ | | | | | | | | | |
| 50 | 2 | 216 | 216 | 232 | 51 | 51 | - | 85 | 180 | 212 | 450 | - | 33 |
| 80 | 3 | 283 | 283 | 298 | 77 | 77 | - | 112 | 230 | 228 | 600 | - | 64 |
| 100 | 4 | 305 | 305 | 321 | 102 | 102 | - | 145 | 283 | 272 | 1000 | - | 123 |
| 150 | 6 | 403 | 403 | 419 | 152 | 152 | 281 | 220 | 325 | 345 | 360 | 500 | 275 |
| 200 | 8 | 502 | 521 | 518 | 203 | 203 | 330 | 260 | 405 | 385 | 340 | 700 | 505 |
| 250 | 10 | 568 | 559 | 584 | 254 | 254 | 371 | 311 | 490 | 426 | 340 | 700 | 557 |
| 300 | 12 | 648 | 635 | 664 | 305 | 305 | 418 | 366 | 570 | 473 | 340 | 700 | 715 |
| 350 | 14 | 762 | 762 | 778 | 337 | 337 | 470 | 428 | 660 | 530 | 545 | 700 | 932 |
| 400 | 16 | 838 | 838 | 854 | 387 | 387 | 477 | 450 | 700 | 537 | 545 | 700 | 1360 |
| 450 | 18 | 914 | 914 | 930 | 438 | 438 | 522 | 473 | 755 | 597 | 575 | 700 | 1840 |
| 500 | 20 | 991 | 991 | 1010 | 489 | 489 | 573 | 580 | 880 | 663 | 579 | 700 | 2340 |
| 550 | 22 | 1092 | 1092 | 1114 | 540 | 540 | 600 | 590 | 965 | 690 | 579 | 700 | 3320 |
| 600 | 24 | 1143 | 1143 | 1165 | 591 | 591 | 631 | 600 | 1040 | 721 | 579 | 700 | 3870 |
| 650 | 26 | 1245 | 1245 | 1270 | 635 | 635 | 702 | 635 | 1085 | 874 | 605 | 620 | 4655 |
| 700 | 28 | 1346 | 1346 | 1372 | 686 | 686 | 764 | 700 | 1175 | 919 | 950 | 1400 | 5575 |
| 750 | 30 | 1397 | 1397 | 1422 | 736 | 736 | 827 | 775 | 1265 | 982 | 950 | 1400 | 6825 |
| 800 | 32 | 1524 | 1524 | 1553 | 781 | 781 | 874 | 825 | 1340 | 1029 | 950 | 1400 | 8490 |
| 850 | 34 | 1626 | 1626 | 1654 | 832 | 832 | 910 | 880 | 1425 | 1065 | 950 | 1400 | 9335 |
| 900 | 36 | 1727 | 1727 | 1756 | 876 | 876 | 968 | 930 | 1490 | 1123 | 950 | 1400 | 10900 |
| 1000 | 40 | 1956 | 1956 | - | 978 | 978 | 1056 | 1025 | 1655 | 1211 | 950 | 1400 | 15185 |
| 1050 | 42 | 2083 | 2083 | - | 1022 | 1022 | 1107 | 1080 | 1725 | 1262 | 950 | 1400 | 17820 |
| 1200 | 48 | 2170 | 2170 | - | 1168 | 1168 | 1228 | 1225 | 1960 | 1499 | 1045 | 1400 | 26675 |

Class 300 Reduced Port

mm

| DN (mm) | NPS (in) | L | | | B | B1 | D | E | F | H | L1 | W | Weight (kg) RF |
|------------|-------------|------|------|------|-----|-----|-----|-----|------|-----|------|------|-------------------|
| | | RF | BW | RTJ | | | | | | | | | |
| 50 × 40 | 2 × 1 1/2 | 216 | 216 | 232 | 38 | 51 | - | 85 | 180 | 212 | 450 | - | 29 |
| 80 × 50 | 3 × 2 | 283 | 283 | 298 | 51 | 77 | - | 85 | 180 | 212 | 450 | - | 43 |
| 100 × 80 | 4 × 3 | 305 | 305 | 321 | 77 | 102 | - | 112 | 230 | 228 | 600 | - | 88 |
| 150 × 100 | 6 × 4 | 403 | 403 | 419 | 102 | 152 | - | 145 | 283 | 272 | 1000 | - | 164 |
| 200 × 150 | 8 × 6 | 502 | 521 | 518 | 152 | 203 | 281 | 220 | 325 | 345 | 360 | 500 | 311 |
| 250 × 200 | 10 × 8 | 568 | 559 | 584 | 203 | 254 | 330 | 260 | 405 | 385 | 340 | 700 | 563 |
| 300 × 250 | 12 × 10 | 648 | 635 | 664 | 254 | 305 | 371 | 311 | 490 | 426 | 340 | 700 | 598 |
| 350 × 250 | 14 × 10 | 762 | 762 | 778 | 254 | 337 | 371 | 311 | 490 | 426 | 340 | 700 | 809 |
| 350 × 300 | 14 × 12 | 762 | 762 | 778 | 305 | 337 | 418 | 366 | 570 | 473 | 340 | 700 | 960 |
| 400 × 300 | 16 × 12 | 838 | 838 | 854 | 305 | 387 | 418 | 366 | 570 | 473 | 340 | 700 | 1135 |
| 400 × 350 | 16 × 14 | 838 | 838 | 854 | 387 | 337 | 470 | 428 | 660 | 530 | 545 | 700 | 1120 |
| 450 × 400 | 18 × 16 | 914 | 914 | 930 | 387 | 438 | 477 | 450 | 700 | 537 | 545 | 700 | 1518 |
| 500 × 400 | 20 × 16 | 991 | 991 | 1010 | 387 | 489 | 477 | 450 | 700 | 537 | 545 | 700 | 1865 |
| 500 × 450 | 20 × 18 | 991 | 991 | 1010 | 438 | 489 | 522 | 473 | 755 | 597 | 575 | 700 | 2110 |
| 600 × 500 | 24 × 20 | 1143 | 1143 | 1165 | 489 | 591 | 573 | 580 | 880 | 663 | 579 | 700 | 2860 |
| 750 × 600 | 30 × 24 | 1397 | 1397 | 1422 | 591 | 736 | 631 | 600 | 1040 | 721 | 579 | 700 | 4810 |
| 900 × 750 | 36 × 30 | 1727 | 1727 | 1756 | 736 | 876 | 827 | 775 | 1265 | 982 | 950 | 1400 | 8440 |

Class 600 Trunnion mounted top entry ball valve

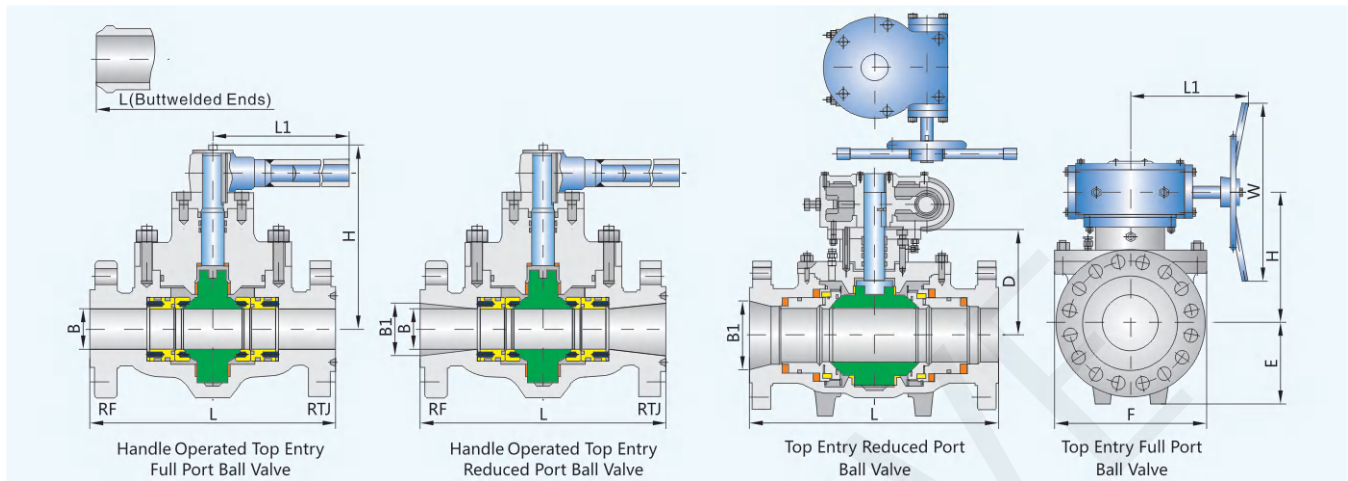

■ Main Outline Dimensions

Class 600 Full Port

mm

| DN (mm) | NPS (in) | L | | | B | B1 | D | E | F | H | L1 | W | Weight (kg) RF |
|---------|----------|------|------|------|------|------|------|------|------|------|------|------|----------------|
| | | RF | BW | RTJ | | | | | | | | | |
| 50 | 2 | 292 | 292 | 295 | 51 | 51 | - | 85 | 180 | 212 | 600 | - | 37 |
| 80 | 3 | 356 | 356 | 359 | 77 | 77 | - | 112 | 230 | 228 | 600 | - | 72 |
| 100 | 4 | 432 | 432 | 435 | 102 | 102 | - | 145 | 283 | 250 | 1000 | - | 137 |
| 150 | 6 | 559 | 559 | 562 | 152 | 152 | 281 | 220 | 325 | 336 | 1000 | 700 | 302 |
| 200 | 8 | 660 | 660 | 664 | 203 | 203 | 340 | 260 | 415 | 395 | 340 | 700 | 560 |
| 250 | 10 | 787 | 787 | 791 | 254 | 254 | 355 | 311 | 505 | 415 | 340 | 700 | 710 |
| 300 | 12 | 838 | 838 | 841 | 305 | 305 | 401 | 366 | 585 | 461 | 545 | 700 | 910 |
| 350 | 14 | 889 | 889 | 892 | 337 | 337 | 451 | 428 | 680 | 526 | 575 | 700 | 1190 |
| 400 | 16 | 991 | 991 | 994 | 387 | 387 | 493 | 450 | 730 | 568 | 575 | 700 | 1735 |
| 450 | 18 | 1092 | 1092 | 1095 | 438 | 438 | 539 | 473 | 784 | 629 | 575 | 700 | 2350 |
| 500 | 20 | 1194 | 1194 | 1200 | 489 | 489 | 592 | 580 | 900 | 682 | 579 | 700 | 3000 |
| 550 | 22 | 1295 | 1295 | 1305 | 540 | 540 | 621 | 590 | 890 | 711 | 579 | 700 | 4240 |
| 600 | 24 | 1397 | 1397 | 1407 | 591 | 591 | 653 | 600 | 1070 | 808 | 950 | 1400 | 4950 |
| 650 | 26 | 1448 | 1448 | 1461 | 635 | 635 | 725 | 635 | 1115 | 880 | 950 | 1400 | 5950 |
| 700 | 28 | 1549 | 1549 | 1562 | 686 | 686 | 790 | 700 | 1210 | 945 | 950 | 1400 | 7130 |
| 750 | 30 | 1651 | 1651 | 1664 | 736 | 736 | 850 | 775 | 1300 | 1005 | 950 | 1400 | 8730 |
| 800 | 32 | 1778 | 1778 | 1794 | 781 | 781 | 900 | 825 | 1380 | 1055 | 950 | 1400 | 10850 |
| 850 | 34 | 1930 | 1930 | 1946 | 832 | 832 | 940 | 880 | 1460 | 1095 | 950 | 1400 | 11930 |
| 900 | 36 | 2083 | 2083 | 2099 | 876 | 876 | 1000 | 930 | 1535 | 1155 | 950 | 1400 | 13950 |
| 1000 | 40 | 2337 | 2337 | 2337 | 978 | 978 | 1090 | 1025 | 1700 | 1360 | 1045 | 1400 | 16420 |
| 1050 | 42 | 2437 | 2437 | 2437 | 1022 | 1022 | 1140 | 1080 | 1775 | 1410 | 1045 | 1400 | 22350 |
| 1200 | 48 | 2540 | 2540 | 2540 | 1168 | 1168 | 1270 | 1225 | 2015 | 1570 | 1080 | 1400 | 32340 |

Class 600 Reduced Port

mm

| DN (mm) | NPS (in) | L | | | B | B1 | D | E | F | H | L1 | W | Weight (kg) RF |
|-----------|-----------|------|------|------|-----|-----|-----|-----|------|------|------|------|----------------|
| | | RF | BW | RTJ | | | | | | | | | |
| 50 x 40 | 2 x 1 1/2 | 292 | 292 | 295 | 38 | 51 | - | 85 | 180 | 212 | 450 | - | 33 |
| 80 x 50 | 3 x 2 | 356 | 356 | 359 | 51 | 77 | - | 85 | 180 | 212 | 600 | - | 48 |
| 100 x 80 | 4 x 3 | 432 | 432 | 435 | 77 | 102 | - | 112 | 230 | 228 | 1000 | - | 97 |
| 150 x 100 | 6 x 4 | 559 | 559 | 562 | 102 | 152 | - | 145 | 283 | 250 | 1000 | - | 181 |
| 200 x 150 | 8 x 6 | 660 | 660 | 664 | 152 | 203 | 281 | 220 | 325 | 336 | 340 | 700 | 340 |
| 250 x 200 | 10 x 8 | 787 | 787 | 791 | 203 | 254 | 340 | 260 | 415 | 395 | 340 | 700 | 625 |
| 300 x 250 | 12 x 10 | 838 | 838 | 841 | 254 | 305 | 355 | 311 | 505 | 415 | 545 | 700 | 760 |
| 350 x 250 | 14 x 10 | 889 | 889 | 892 | 254 | 337 | 355 | 311 | 505 | 415 | 545 | 700 | 1030 |
| 350 x 300 | 14 x 12 | 889 | 889 | 892 | 305 | 337 | 401 | 366 | 585 | 461 | 545 | 700 | 1230 |
| 400 x 300 | 16 x 12 | 991 | 991 | 994 | 305 | 387 | 401 | 366 | 585 | 461 | 545 | 700 | 1450 |
| 400 x 350 | 16 x 14 | 991 | 991 | 994 | 387 | 337 | 451 | 428 | 680 | 526 | 575 | 700 | 1430 |
| 450 x 400 | 18 x 16 | 1092 | 1092 | 1095 | 387 | 438 | 493 | 450 | 730 | 568 | 575 | 700 | 1940 |
| 500 x 400 | 20 x 16 | 1194 | 1194 | 1200 | 387 | 489 | 493 | 450 | 730 | 568 | 575 | 700 | 2380 |
| 500 x 450 | 20 x 18 | 1194 | 1194 | 1200 | 438 | 489 | 539 | 473 | 784 | 629 | 579 | 700 | 2700 |
| 600 x 500 | 24 x 20 | 1397 | 1397 | 1407 | 489 | 591 | 592 | 580 | 900 | 682 | 579 | 700 | 3660 |
| 750 x 600 | 30 x 24 | 1651 | 1651 | 1664 | 591 | 736 | 653 | 600 | 1070 | 808 | 950 | 1400 | 6150 |
| 900 x 750 | 36 x 30 | 2083 | 2083 | 2099 | 736 | 876 | 850 | 775 | 1300 | 1005 | 950 | 1400 | 10800 |

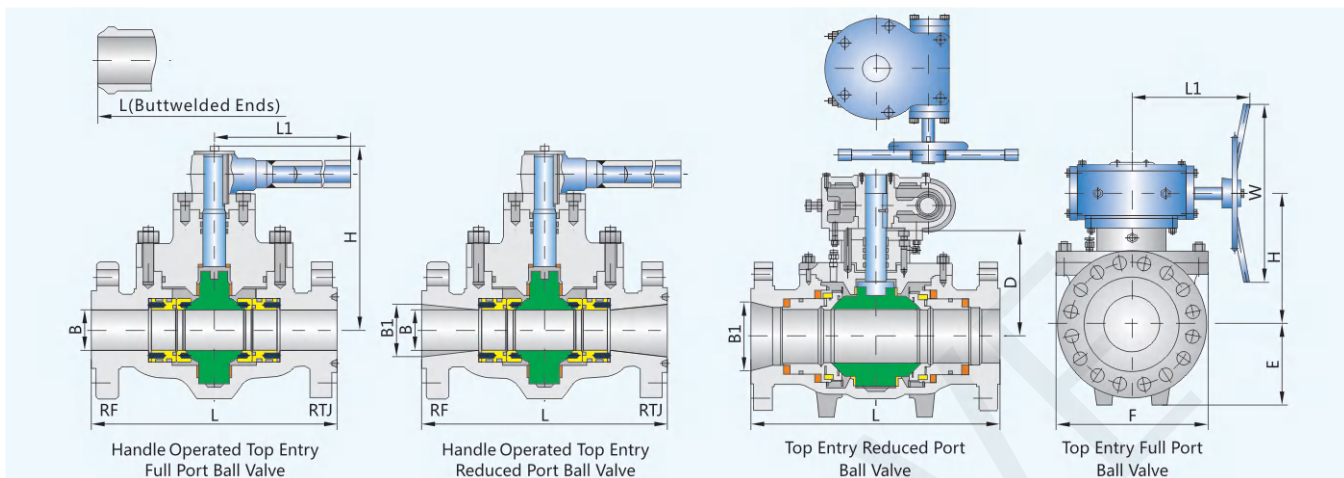

■ Main Outline Dimensions

Class 900 Full Port

mm

| DN (mm) | NPS (in) | L | | | B | B1 | D | E | F | H | L1 | W | Weight (kg) RF |
|---------|----------|------|------|------|-----|-----|------|-----|------|------|------|------|----------------|
| | | RF | BW | RTJ | | | | | | | | | |
| 50 | 2 | 368 | 368 | 371 | 51 | 51 | - | 85 | 195 | 215 | 600 | - | 52 |
| 80 | 3 | 381 | 381 | 384 | 77 | 77 | - | 112 | 240 | 193 | 1000 | - | 108 |
| 100 | 4 | 457 | 457 | 460 | 102 | 102 | 227 | 145 | 295 | 291 | 360 | - | 200 |
| 150 | 6 | 610 | 610 | 613 | 152 | 152 | 258 | 225 | 330 | 313 | 340 | 500 | 456 |
| 200 | 8 | 737 | 737 | 740 | 203 | 203 | 318 | 260 | 425 | 378 | 545 | 700 | 845 |
| 250 | 10 | 838 | 838 | 841 | 254 | 254 | 370 | 320 | 525 | 430 | 545 | 700 | 1070 |
| 300 | 12 | 965 | 965 | 968 | 305 | 305 | 418 | 375 | 600 | 493 | 575 | 700 | 1675 |
| 350 | 14 | 1029 | 1029 | 1038 | 324 | 324 | 470 | 440 | 695 | 545 | 575 | 700 | 1800 |
| 400 | 16 | 1130 | 1130 | 1140 | 375 | 375 | 515 | 465 | 750 | 605 | 579 | 700 | 2650 |
| 450 | 18 | 1219 | 1219 | 1232 | 425 | 425 | 560 | 485 | 800 | 650 | 579 | 700 | 3550 |
| 500 | 20 | 1321 | 1321 | 1334 | 473 | 473 | 620 | 600 | 925 | 775 | 950 | 1400 | 4530 |
| 600 | 24 | 1549 | 1549 | 1568 | 571 | 571 | 680 | 620 | 1095 | 835 | 950 | 1400 | 7450 |
| 650 | 26 | 1651 | 1651 | 1674 | 619 | 619 | 760 | 655 | 1145 | 915 | 950 | 1400 | 8925 |
| 700 | 28 | 1753 | 1753 | 1775 | 667 | 667 | 824 | 720 | 1240 | 979 | 950 | 1400 | 10695 |
| 750 | 30 | 1880 | 1880 | 1902 | 714 | 714 | 886 | 800 | 1335 | 1157 | 950 | 1400 | 13095 |
| 800 | 32 | 2032 | 2032 | 2054 | 762 | 762 | 938 | 848 | 1415 | 1209 | 1045 | 1400 | 16200 |
| 850 | 34 | 2159 | 2159 | 2188 | 810 | 810 | 980 | 905 | 1495 | 1251 | 1045 | 1400 | 17800 |
| 900 | 36 | 2286 | 2286 | 2315 | 857 | 857 | 1042 | 957 | 1570 | 1313 | 1045 | 1400 | 20930 |

Class 900 Reduced Port

mm

| DN (mm) | NPS (in) | L | | | B | B1 | D | E | F | H | L1 | W | Weight (kg) RF |
|-----------|-----------|------|------|------|-----|-----|-----|-----|------|------|------|------|----------------|
| | | RF | BW | RTJ | | | | | | | | | |
| 50 x 40 | 2 x 1 1/2 | 368 | 368 | 371 | 38 | 51 | - | 85 | 195 | 215 | 450 | - | 49 |
| 80 x 50 | 3 x 2 | 381 | 381 | 384 | 51 | 77 | - | 85 | 195 | 215 | 600 | - | 70 |
| 100 x 80 | 4 x 3 | 457 | 457 | 460 | 77 | 102 | - | 112 | 240 | 193 | 1000 | - | 146 |
| 150 x 100 | 6 x 4 | 610 | 610 | 613 | 102 | 152 | 227 | 145 | 295 | 291 | 360 | - | 273 |
| 200 x 150 | 8 x 6 | 737 | 737 | 740 | 152 | 203 | 258 | 225 | 330 | 313 | 340 | 500 | 573 |
| 250 x 200 | 10 x 8 | 838 | 838 | 841 | 203 | 254 | 318 | 260 | 425 | 378 | 545 | 700 | 943 |
| 300 x 250 | 12 x 10 | 965 | 965 | 968 | 254 | 305 | 370 | 320 | 525 | 430 | 545 | 700 | 1150 |
| 350 x 250 | 14 x 10 | 1029 | 1029 | 1038 | 254 | 324 | 370 | 320 | 525 | 430 | 545 | 700 | 1550 |
| 350 x 300 | 14 x 12 | 1029 | 1029 | 1038 | 324 | 305 | 418 | 375 | 600 | 493 | 575 | 700 | 1855 |
| 400 x 300 | 16 x 12 | 1130 | 1130 | 1140 | 305 | 375 | 418 | 375 | 600 | 493 | 575 | 700 | 2185 |
| 400 x 350 | 16 x 14 | 1130 | 1130 | 1140 | 324 | 375 | 470 | 440 | 695 | 545 | 575 | 700 | 2160 |
| 450 x 400 | 18 x 16 | 1219 | 1219 | 1232 | 375 | 425 | 515 | 465 | 750 | 605 | 579 | 700 | 2925 |
| 500 x 400 | 20 x 16 | 1321 | 1321 | 1334 | 375 | 473 | 515 | 465 | 750 | 605 | 579 | 700 | 3590 |
| 500 x 450 | 20 x 18 | 1321 | 1321 | 1334 | 425 | 473 | 560 | 485 | 800 | 650 | 579 | 700 | 4100 |
| 600 x 500 | 24 x 20 | 1549 | 1549 | 1568 | 473 | 571 | 620 | 600 | 925 | 775 | 950 | 1400 | 5520 |
| 750 x 600 | 30 x 24 | 1880 | 1880 | 1902 | 571 | 714 | 680 | 620 | 1095 | 835 | 950 | 1400 | 9225 |
| 900 x 750 | 36 x 30 | 2286 | 2286 | 2315 | 714 | 857 | 886 | 800 | 1335 | 1157 | 950 | 1400 | 15700 |

Class 1500 Trunnion mounted top entry ball valve

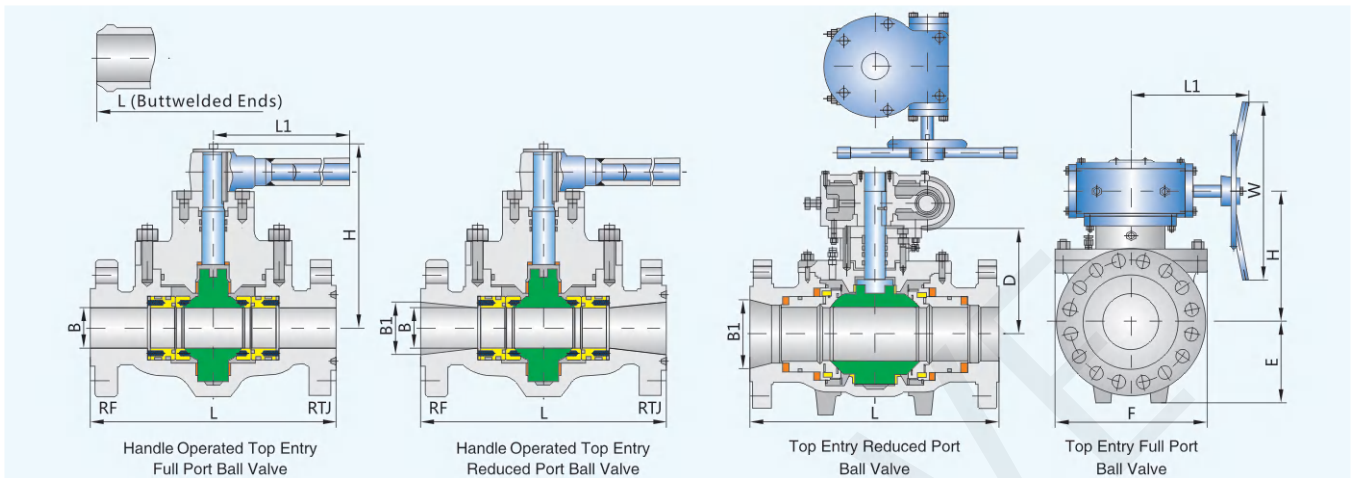

■ Main Outline Dimensions

Class 1500 Full Port

mm

| DN (mm) | NPS (in) | L | | | B | B1 | D | E | F | H | L1 | W | Weight (kg) RF |
|------------|-------------|------|------|------|-----|-----|-----|-----|------|-----|------|------|-------------------|
| | | RF | BW | RTJ | | | | | | | | | |
| 50 | 2 | 368 | 368 | 371 | 51 | 51 | - | 85 | 205 | 179 | 600 | - | 52 |
| 80 | 3 | 470 | 470 | 473 | 77 | 77 | - | 120 | 250 | 201 | 1000 | - | 152 |
| 100 | 4 | 546 | 546 | 549 | 102 | 102 | 240 | 155 | 310 | 295 | 340 | 700 | 280 |
| 150 | 6 | 705 | 705 | 711 | 146 | 146 | 273 | 240 | 370 | 333 | 545 | 700 | 640 |
| 200 | 8 | 832 | 832 | 841 | 194 | 194 | 335 | 280 | 455 | 410 | 575 | 700 | 1180 |
| 250 | 10 | 991 | 991 | 1000 | 241 | 241 | 385 | 340 | 565 | 460 | 575 | 700 | 1500 |
| 300 | 12 | 1130 | 1130 | 1146 | 289 | 289 | 436 | 400 | 670 | 511 | 575 | 700 | 2065 |
| 350 | 14 | 1257 | 1257 | 1276 | 317 | 317 | 485 | 467 | 730 | 575 | 579 | 700 | 2700 |
| 400 | 16 | 1384 | 1384 | 1407 | 362 | 362 | 530 | 495 | 790 | 620 | 579 | 700 | 3980 |
| 450 | 18 | 1537 | 1537 | 1559 | 407 | 407 | 585 | 520 | 840 | 740 | 950 | 1400 | 5325 |
| 500 | 20 | 1664 | 1664 | 1686 | 457 | 457 | 640 | 639 | 965 | 795 | 950 | 1400 | 6800 |
| 600 | 24 | 2043 | 2043 | 2071 | 534 | 534 | 708 | 640 | 1145 | 979 | 1045 | 1400 | 11900 |

Class 1500 Reduced Port

mm

| DN (mm) | NPS (in) | L | | | B | B1 | D | E | F | H | L1 | W | Weight (kg) RF |
|------------|-------------|------|------|------|-----|-----|-----|-----|-----|-----|------|-----|-------------------|
| | | RF | BW | RTJ | | | | | | | | | |
| 50 × 40 | 2 × 1 1/2 | 368 | 368 | 371 | 38 | 51 | - | 85 | 205 | 179 | 450 | - | 49 |
| 80 × 50 | 3 × 2 | 470 | 470 | 473 | 51 | 77 | - | 85 | 205 | 179 | 600 | - | 98 |
| 100 × 80 | 4 × 3 | 546 | 546 | 549 | 77 | 102 | - | 120 | 250 | 201 | 1000 | - | 205 |
| 150 × 100 | 6 × 4 | 705 | 705 | 711 | 102 | 146 | 240 | 155 | 310 | 295 | 340 | 700 | 382 |
| 200 × 150 | 8 × 6 | 832 | 832 | 841 | 146 | 194 | 273 | 240 | 370 | 333 | 545 | 700 | 720 |
| 250 × 200 | 10 × 8 | 991 | 991 | 1000 | 194 | 241 | 335 | 280 | 455 | 410 | 575 | 700 | 1320 |
| 300 × 250 | 12 × 10 | 1130 | 1130 | 1146 | 241 | 289 | 385 | 340 | 565 | 460 | 575 | 700 | 1600 |
| 350 × 250 | 14 × 10 | 1257 | 1257 | 1276 | 241 | 317 | 385 | 340 | 565 | 460 | 575 | 700 | 2170 |
| 350 × 300 | 14 × 12 | 1257 | 1257 | 1276 | 317 | 317 | 436 | 400 | 565 | 460 | 575 | 700 | 2780 |
| 400 × 300 | 16 × 12 | 1384 | 1384 | 1407 | 289 | 362 | 436 | 400 | 670 | 511 | 575 | 700 | 3280 |
| 400 × 350 | 16 × 14 | 1384 | 1384 | 1407 | 317 | 362 | 485 | 467 | 670 | 511 | 579 | 700 | 3240 |

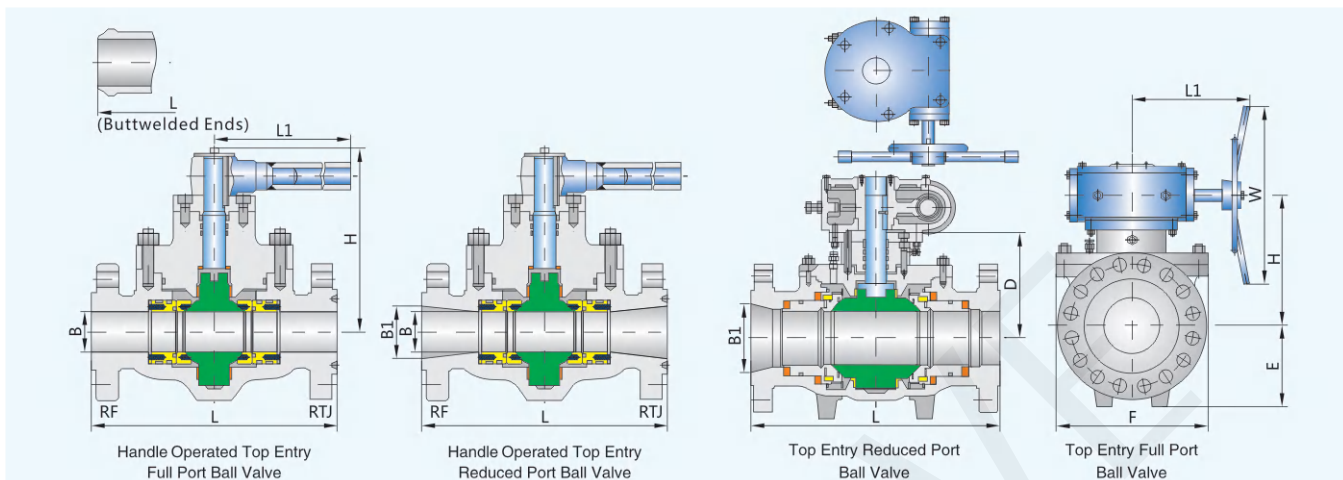

■ Main Outline Dimensions

Class 2500 Full Port

mm

| DN (mm) | NPS (in) | L | | | B | B1 | D | E | F | H | L1 | W | Weight (kg) RF |
|---------|----------|------|------|------|------|------|-----|-----|-----|-----|-----|-----|----------------|
| | | RF | BW | RTJ | | | | | | | | | |
| 50 | 2 | 451 | 451 | 454 | 44.5 | 44.5 | 198 | 105 | 270 | 250 | 297 | 300 | 120 |
| 80 | 3 | 578 | 578 | 584 | 63.5 | 63.5 | 250 | 127 | 350 | 305 | 340 | 700 | 246 |
| 100 | 4 | 673 | 673 | 683 | 89 | 89 | 305 | 156 | 400 | 360 | 340 | 700 | 470 |
| 150 | 6 | 914 | 914 | 927 | 133 | 133 | 355 | 240 | 480 | 430 | 575 | 700 | 937 |
| 200 | 8 | 1022 | 1022 | 1038 | 181 | 181 | 438 | 280 | 530 | 513 | 575 | 700 | 1410 |
| 250 | 10 | 1270 | 1270 | 1292 | 226 | 226 | 530 | 365 | 720 | 620 | 590 | 700 | 2600 |
| 300 | 12 | 1422 | 1422 | 1445 | 267 | 267 | 590 | 430 | 860 | 740 | 505 | 620 | 4200 |

Class 2500 Reduced Port

mm

| DN (mm) | NPS (in) | L | | | B | B1 | D | E | F | H | L1 | W | Weight (kg) RF |
|-----------|-----------|------|------|------|------|------|-----|-----|-----|-----|-----|-----|----------------|
| | | RF | BW | RTJ | | | | | | | | | |
| 50 × 40 | 2 × 1 1/2 | 451 | 451 | 454 | 38 | 44.5 | - | 93 | 250 | 150 | 600 | - | 80 |
| 80 × 50 | 3 × 2 | 578 | 578 | 584 | 44.5 | 63.5 | 198 | 105 | 270 | 250 | 297 | 300 | 160 |
| 100 × 80 | 4 × 3 | 673 | 673 | 683 | 63.5 | 89 | 250 | 127 | 350 | 305 | 340 | 700 | 300 |
| 150 × 100 | 6 × 4 | 914 | 914 | 927 | 89 | 133 | 305 | 156 | 400 | 360 | 340 | 700 | 670 |
| 200 × 150 | 8 × 6 | 1022 | 1022 | 1038 | 133 | 181 | 355 | 240 | 480 | 430 | 575 | 700 | 1150 |
| 250 × 200 | 10 × 8 | 1270 | 1270 | 1292 | 181 | 226 | 438 | 280 | 530 | 513 | 575 | 700 | 2100 |
| 300 × 250 | 12 × 10 | 1422 | 1422 | 1445 | 226 | 267 | 530 | 365 | 720 | 620 | 590 | 700 | 3300 |

Product structural features

Ball valve according to DIN is applicable to the cutting and connection of pipelines medium that are used in various industries such as petroleum, chemical industry, pharmacy, chemical fertilizer, electric power industry etc under nominal pressure of PN1.6~10MPa and working temperature within -196~250°C.

Main structural features

1. The product has indication of open-close and locking system;
2. The stem has function of anti-blow out, anti fire-safe and anti-static function;
3. The part material flange, and butting weld end dimension may be selected according to current operation condition and user's requirement, so that meeting the requirement of various engineering.

Technical specification

Structural Formation: Bolted, split body, side entry

Driving Manner: Hand-Operated

Driving Manner: Electric-Actuated

Design Standard: DIN3356

Face to Face: DIN3202, EN558-1

Flange Ends: DIN2543-2545, EN1092-1

Test & Inspection: DIN3230, ISO 5208

Notes: The size of serial, valve connecting flange can be design according to customers' requirement

Products performance specification

| Nominal Pressure(MPa) | Shell Test (MPa) | Sealing Test (MPa) | Suitable Temp(°C) | Suitable Medium |
|-----------------------|------------------|--------------------|-------------------|-----------------|
| 1.6 | 2.4 | 1.76 | -196~150°C | Water Oil & Gas |
| 2.5 | 3.75 | 2.75 | | |
| 4.0 | 6.0 | 4.4 | | |
| 6.4 | 9.6 | 7.04 | | |
| 10.0 | 10.5 | 11 | | |

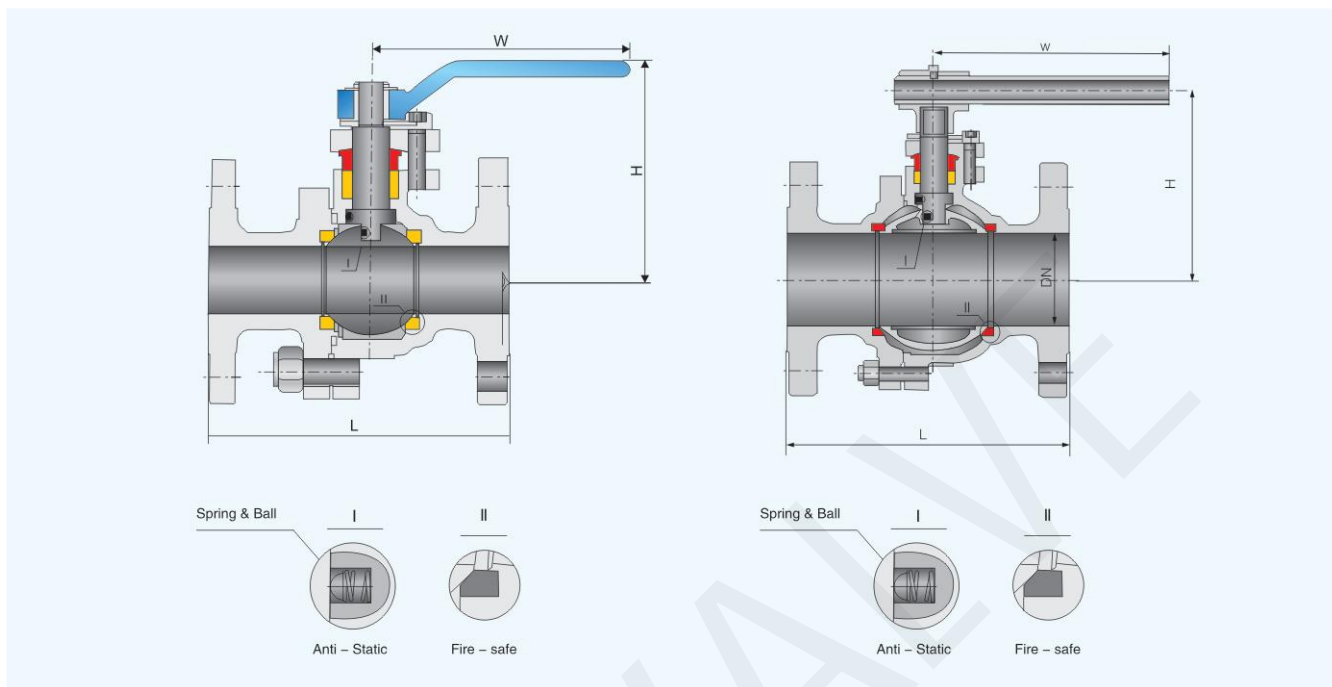

■ **Main dimensions of Floating Ball Valve**

| PN 16 | | | | | | | | | | | | |
|--------|-----|-----|-----|-----|-----|-----|-----|-----|-----|-----|-----|------|
| DN | 15 | 20 | 25 | 32 | 40 | 50 | 65 | 80 | 100 | 125 | 150 | 200 |
| L | 130 | 140 | 150 | 165 | 180 | 200 | 220 | 250 | 280 | 320 | 360 | 400 |
| H | 78 | 84 | 95 | 150 | 150 | 190 | 195 | 215 | 250 | 285 | 330 | 370 |
| H1 | 140 | 160 | 180 | 250 | 300 | 350 | 350 | 400 | 600 | 600 | 800 | 1000 |
| WT(Kg) | 3 | 4 | 5 | 10 | 14 | 20 | 25 | 30 | 40 | 65 | 73 | 85 |
| PN 25 | | | | | | | | | | | | |
| DN | 15 | 20 | 25 | 32 | 40 | 50 | 65 | 80 | 100 | 125 | 150 | 200 |
| L | 130 | 140 | 150 | 165 | 180 | 200 | 220 | 250 | 280 | 320 | 360 | 400 |
| H | 78 | 84 | 95 | 150 | 150 | 190 | 195 | 215 | 250 | 285 | 330 | 370 |
| H1 | 140 | 160 | 180 | 250 | 300 | 350 | 350 | 400 | 600 | 600 | 800 | 1000 |
| WT(Kg) | 3 | 4 | 5 | 10 | 14 | 20 | 25 | 30 | 40 | 65 | 73 | 85 |
| PN 40 | | | | | | | | | | | | |
| DN | 15 | 20 | 25 | 32 | 40 | 50 | 65 | 80 | 100 | 125 | 150 | 200 |
| L | 130 | 140 | 150 | 165 | 180 | 200 | 220 | 250 | 280 | 403 | 403 | 502 |
| H | 82 | 100 | 104 | 150 | 150 | 190 | 195 | 215 | 250 | 260 | 275 | 335 |
| H1 | 140 | 160 | 180 | 250 | 300 | 350 | 350 | 400 | 600 | 600 | 800 | 800 |
| WT(Kg) | 3 | 4 | 5 | 10 | 14 | 20 | 25 | 50 | 70 | 80 | 85 | 101 |

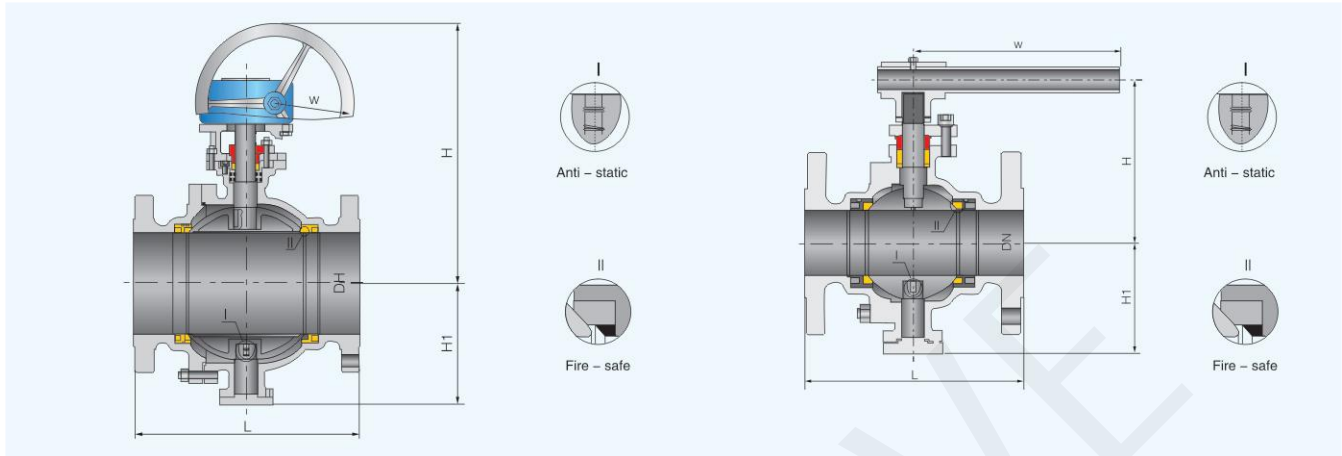

■ Main dimensions of Trunnion Ball Valve

| PN 16/25 | | | | | | | | | | | | | | | | | | | |
|----------|-----|-----|-----|-----|------|------|-----|-----|------|------|------|------|------|------|------|------|------|-------|------|
| DN | 50 | 65 | 80 | 100 | 125 | 150 | 200 | 250 | 300 | 350 | 400 | 450 | 500 | 600 | 700 | 800 | 900 | 1000 | |
| L | R F | 179 | 191 | 203 | 229 | 356 | 394 | 457 | 533 | 610 | 686 | 762 | 846 | 914 | 1067 | 1245 | 1372 | 1524 | 1753 |
| | B W | 216 | 241 | 283 | 305 | 381 | 457 | 521 | 559 | 635 | 762 | 838 | 914 | 991 | 1143 | 1346 | 1524 | 1727 | 1880 |
| H | 107 | 125 | 152 | 178 | 300 | 330 | 398 | 495 | 580 | 625 | 670 | 698 | 840 | 1050 | 1100 | 1150 | 1247 | 1374 | |
| H1 | 102 | 114 | 127 | 152 | 184 | 219 | 273 | 360 | 395 | 430 | 470 | 550 | 580 | 700 | 800 | 950 | 1100 | 1200 | |
| W | 230 | 400 | 400 | 650 | 1050 | 105 | 600 | 600 | 800 | 800 | 800 | 800 | 800 | 800 | 800 | 800 | 800 | 800 | |
| WT(Kg) | 12 | 16 | 22 | 35 | 58 | 74 | 205 | 322 | 460 | 576 | 864 | 1280 | 1600 | 3540 | 4500 | 5940 | 7540 | 9320 | |
| PN 40 | | | | | | | | | | | | | | | | | | | |
| DN | 50 | 65 | 80 | 100 | 125 | 150 | 200 | 250 | 300 | 350 | 400 | 450 | 500 | 600 | 700 | 800 | 900 | 1000 | |
| L | R F | 216 | 241 | 283 | 305 | 381 | 403 | 502 | 568 | 648 | 762 | 838 | 914 | 991 | 1143 | 1346 | 1524 | 1727 | 1880 |
| | B W | 216 | 241 | 283 | 305 | 381 | 457 | 521 | 559 | 635 | 762 | 838 | 914 | 991 | 1143 | 1346 | 1524 | 1727 | 1880 |
| H | 107 | 125 | 152 | 178 | 300 | 330 | 398 | 495 | 580 | 625 | 670 | 698 | 840 | 1050 | 1100 | 1150 | 1247 | 1374 | |
| H1 | 102 | 114 | 127 | 152 | 184 | 219 | 273 | 360 | 395 | 430 | 470 | 550 | 580 | 700 | 800 | 950 | 1100 | 1200 | |
| W | 230 | 400 | 400 | 650 | 1050 | 1050 | 600 | 600 | 800 | 800 | 800 | 800 | 800 | 800 | 800 | 800 | 800 | 800 | |
| WT(Kg) | 15 | 24 | 30 | 55 | 87 | 118 | 255 | 370 | 533 | 640 | 1030 | 1542 | 2100 | 4200 | 5300 | 7860 | 8684 | 10300 | |
| PN 64 | | | | | | | | | | | | | | | | | | | |
| DN | 50 | 65 | 80 | 100 | 150 | 200 | 250 | 300 | 350 | 400 | 500 | 600 | 700 | | | | | | |
| L | R F | 292 | 330 | 356 | 406 | 495 | 597 | 673 | 762 | 826 | 902 | 1054 | 1232 | 1397 | | | | | |
| | H | 108 | 155 | 197 | 235 | 300 | 374 | 445 | 512 | 550 | 615 | 810 | 1010 | 1180 | | | | | |
| H1 | 114 | 124 | 133 | 159 | 250 | 294 | 395 | 445 | 500 | 530 | 660 | 800 | 900 | | | | | | |
| W | 600 | 600 | 600 | 600 | 600 | 800 | 800 | 800 | 800 | 800 | 800 | 800 | 800 | | | | | | |
| WT(Kg) | 23 | 35 | 49 | 91 | 192 | 355 | 640 | 880 | 1100 | 1540 | 2800 | 5300 | 5700 | | | | | | |
| PN 100 | | | | | | | | | | | | | | | | | | | |
| DN | 50 | 65 | 80 | 100 | 150 | 200 | 250 | 300 | 350 | 400 | 500 | 600 | 700 | | | | | | |
| L | R F | 292 | 330 | 356 | 432 | 559 | 660 | 787 | 838 | 889 | 991 | 1194 | 1397 | 1579 | | | | | |
| | H | 108 | 155 | 197 | 235 | 300 | 374 | 445 | 512 | 550 | 615 | 810 | 1010 | 1180 | | | | | |
| H1 | 114 | 124 | 133 | 159 | 250 | 294 | 395 | 445 | 500 | 530 | 660 | 800 | 900 | | | | | | |
| W | 600 | 600 | 600 | 600 | 600 | 800 | 800 | 800 | 800 | 800 | 800 | 800 | 800 | | | | | | |
| WT(Kg) | 23 | 38 | 55 | 102 | 232 | 290 | 710 | 960 | 1700 | 1970 | 3250 | 5800 | 6700 | | | | | | |